



# **Operator's Manual**

## **RespSense™ II Model LS1R**

### **Capnography Monitor**

**R<sub>X</sub> Only**

**CE** 0123

**English**

Nonin makes no claim for use of the product other than those uses specified herein and disclaims any liability resulting from other uses. Observe all warnings, cautions, and notes.

Unauthorized use, copying, or distribution of this manual is prohibited without written consent from Nonin Medical, Inc.

 **Nonin Medical, Inc.**  
13700 1st Avenue North  
Plymouth, MN 55441, USA

+1 (763) 553-9968 (outside USA)  
(800) 356-8874 (USA and Canada)  
Fax: +1 (763) 553-7807  
E-mail: [info@nonin.com](mailto:info@nonin.com)

**Nonin Medical B.V.**  
Prins Hendriklaan 26  
1075 BD Amsterdam, Netherlands

+31 (0)13 - 79 99 040 (Europe)  
Fax: +31 (0)13 - 79 99 042  
E-mail: [infointl@nonin.com](mailto:infointl@nonin.com)

[nonin.com](http://nonin.com)



MPS, Medical Product Service GmbH  
Borngasse 20  
D-35619 Braunfels, Germany

References to “Nonin” in this manual imply Nonin Medical, Inc. Nonin and RespSense are registered trademarks or trademarks of Nonin Medical, Inc. Other trademarks and trade names are those of their respective owners.

© 2016 Nonin Medical, Inc.  
111332-001-0G

# Contents

<b>Indications for Use .....</b>	<b>1</b>
Warnings .....	1
Cautions .....	2
<b>Guide to Symbols .....</b>	<b>4</b>
<b>Introduction.....</b>	<b>6</b>
About RespSense II.....	6
About Capnometry.....	6
<b>System Components .....</b>	<b>7</b>
RespSense II Monitor .....	8
Rechargeable Battery.....	10
Battery Replacement .....	11
Sample Line.....	11
Intended Use.....	11
Applying the Sample Line .....	11
Nafion Tubing .....	12
Attaching the Nafion Tubing.....	12
Single-Patient Use, Disposable Moisture Trap and Filter.....	12
Replacing the Moisture Trap/Filter .....	12
PSG DAC Cables .....	13
Capno RTC Cable .....	13
<b>Display Screens .....</b>	<b>14</b>
Select Alarm Group Screen.....	14
Operating Screen .....	16
<b>Using the RespSense II Monitor.....</b>	<b>19</b>
Start-up Sequence.....	19
Shut Down Modes .....	19
Standby Mode.....	19
Deep Sleep Mode .....	20
System Setup .....	20
Monitoring a Patient.....	21
Configuration Menu .....	22
Language/Units Screen .....	23
Responsible Organization Settings Screen.....	24
Minimum Alarm Volume.....	25
Default Alarm Volume .....	25
Alarm Limits – EtCO <sub>2</sub> , RR.....	25
Reset Device to Factory Defaults .....	26
New PIN.....	26
Factory Service .....	26
Date/Time Screen.....	27
Alarm Lock Mode Screen .....	27
Calibration Screen .....	28
Calibration Procedure .....	28

## Contents (Continued)

<b>Alarm Limit Settings</b> .....	<b>30</b>
Alarm Limits .....	30
<b>Alarms</b> .....	<b>31</b>
High Priority Alarms .....	32
Medium Priority Alarms .....	33
Inoperable Alarms .....	33
<b>Data Output and Software</b> .....	<b>34</b>
Device Memory .....	34
Download Patient Data .....	34
USB Drive Requirements.....	34
Recommended SanDisk® USB Flash Drives .....	34
Download Data from the Monitor .....	35
Clear Memory.....	35
Data Format .....	36
Monitor Software .....	37
Connecting the Device into a Medical System .....	38
<b>Maintenance and Inspection</b> .....	<b>39</b>
Maintenance.....	39
Ensuring Optimal Performance.....	39
Cleaning the Monitor.....	39
Recommended Inspections and Functional Check.....	40
<b>Troubleshooting</b> .....	<b>41</b>
<b>Accessories</b> .....	<b>45</b>
<b>Service, Support, and Warranty</b> .....	<b>47</b>
Warranty.....	47
<b>Technical Information</b> .....	<b>48</b>
Operating Environment .....	48
Storage Environment .....	48
Power Requirements.....	48
Manufacturer’s Declaration .....	49
Equipment Response Time.....	51
System Specifications .....	52
Capnography Specifications .....	53

## Figures

Figure 1. Monitor Features .....	8
Figure 2. Replacing the Moisture Trap/Filter .....	13
Figure 3. Select Alarm Group Screen .....	14
Figure 4. Operating Screen .....	16
Figure 5. Start-up Screen .....	19
Figure 6. Access Configuration Menu (Nonin Logo) .....	22
Figure 7. Configuration Menu .....	22
Figure 8. Language/Units Screen.....	23
Figure 9. Responsible Organization Settings Screen.....	24
Figure 10. Date/Time Screen .....	27
Figure 11. Alarm Lock Mode Screen.....	28
Figure 12. Calibration Screen.....	29
Figure 13. Operating Screen with Alarms .....	31
Figure 14. Sample Patient Data (_gd.csv File).....	36
Figure 15. Sample Capnography Waveform Data (_cw.csv File) .....	36

## Tables

Table 1. Symbols .....	4
Table 2. Monitor Features.....	9
Table 3. Select Alarm Group Screen – Display Descriptions.....	15
Table 4. Operating Screen – Display Descriptions .....	16
Table 5. Alarm Limit Settings .....	30
Table 6. High Priority Alarms .....	32
Table 7. Medium Priority Alarms .....	33
Table 8. Inoperable Alarms.....	33
Table 9. Electromagnetic Emissions.....	49
Table 10. Electromagnetic Immunity.....	49
Table 11. Guidance and Manufacturer’s Declaration—Electromagnetic Immunity..	50
Table 12. Recommended Separation Distances .....	51



## Indications for Use

The RespSense II, Model LS1R, capnography monitor is indicated for use in simultaneously measuring, displaying, monitoring, and recording end tidal carbon dioxide (EtCO<sub>2</sub>) and respiration rate of adult, pediatric, and infant patients. It is intended for use in environments where patients require continuous, non-invasive monitoring of these parameters by a healthcare professional, including hospitals, long-term care, medical facilities, sleep laboratories, home healthcare, subacute environments, and Emergency Medical Services (EMS), including patient transport.

<b>Contraindication:</b> Do not use the monitor in an MR environment or in the presence of flammable anesthetics or gases.
--

## Warnings

This system is not intended to be used simultaneously on multiple patients.
This device is intended only as an adjunct device in patient assessment. It must be used in conjunction with other methods of assessing clinical signs and symptoms.
The monitor is not classified as an apnea monitor.
This monitor is not intended for use with inhalation halogenated agents.
Verify all alarm settings and limits during system start-up to ensure that they are set as intended.
Before each use, it is the operator's responsibility to verify that the alarm limits are appropriate for the patient being monitored.
Ensure that all alarm volumes are audible in all situations. Do not cover or obstruct any speaker openings.
When turning on the monitor, verify that a beep is heard. If a beep is not heard, do not use the device. The speaker may not be functioning properly.
Atmospheric pressure compensation occurs during system startup. <ul style="list-style-type: none"> <li>- An increase in the surrounding environment's atmospheric pressure may cause the system to display incorrect readings until the system stabilizes.</li> <li>- A decrease in the surrounding environment's atmospheric pressure may cause the system to not detect an occlusion when the condition exists.</li> </ul>
A hazard can exist if different presets are used on multiple RespSense II monitors in one care area.
To prevent improper performance and/or patient injury, verify compatibility of the monitor and accessories before use.
No modifications to this device are allowed as it may affect device performance.
Never allow liquids to enter into or to be spilled onto the monitor. If liquid has penetrated into the monitor, it must be checked by Nonin Technical Service.
This device is only defibrillation proof when used with Nonin-specified power supplies, cables, and accessories. To avoid patient injury, only use Nonin-specified power supplies, cables, and accessories (see Accessories).
The monitor displays a flashing yellow battery indicator (low battery) when it has approximately 60 minutes of use remaining before it shuts itself off.
This device should not be used adjacent to or stacked with other equipment. If adjacent or stacked use is necessary, the device should be observed carefully to verify normal operation.
Prior to connecting the monitor to the power supply and a power outlet, be sure to verify the voltage and frequency rating on the power supply are the same as the outlet. If this is not the case, do not connect the monitor and power supply to the outlet.

## Warnings (Continued)

The use of accessories other than those specified in this manual may result in increased electromagnetic emission and/or decreased immunity of this device.

As with all medical equipment, carefully route cables and cannula to reduce the possibility of entanglement, strangulation, or tripping.

## Cautions

RespSense II should only be operated by trained licensed practitioners.

To prevent damage to the monitor, operate and store the monitor in an upright position.

Visually inspect the monitor for damage before each use. Do not use a damaged monitor or system.

Verify display functionality before each use.

Setting alarm limits to extremes can render the alarm system useless.

Each time the system is turned on, audible alarms are silenced for 2 minutes unless the operator presses the Audio Pause button.

When an alarm is acknowledged and audible alarms are paused, new alarms will have visual indicators, but not an audible indicator.

Capnography alarms are not active until the first breath is detected.

To ensure the longevity and safety of the monitor, the carrying case must be used when operating the monitor in an emergency medical services (EMS) environment.

Do not mount the monitor directly above the patient. If the monitor is mounted, be sure to check that the adjustable mounting clamp is securely affixed.

When mounting the monitor to a mobile pole, mounting the monitor higher than 1.5 meters (5 feet) or mounting more than 2 kilograms (4.5 pounds) of equipment onto the pole may result in tipping, damage to the equipment, or injury.

Always turn off the monitor prior to cleaning the monitor. Do not place the device in liquid or clean it with agents containing ammonium chloride or bleach. Do not sterilize or autoclave the monitor or accessories.

Do not simultaneously touch the accessible connector pins and the patient.

After exposing the monitor to an environment outside of normal room temperature/humidity conditions, always replace the moisture trap and filter before each use.

The sample line, moisture trap, filter, and Nafion tubing are single-patient use, disposable components. Do not reuse disposable accessories. Accessories marked "single-use" must be used on one patient only and be disposed of after usage. Dispose of all components in accordance with your local, state or national regulations regarding waste management.

Set or adjust alarm parameters one at a time.

The patient's nasal passage may dry out if continuous monitoring is required. Check patient hourly for nasal comfort.

When using sample lines that also deliver oxygen to the patient, it is important to be aware that the EtCO<sub>2</sub> value may be diluted when used in combination with supplemental oxygen. To obtain a true EtCO<sub>2</sub> reading, it is recommended that the supplemental oxygen be disconnected for a few seconds to establish a baseline.

If the EtCO<sub>2</sub> value is out of normal range (4.4 – 5.7 Vol%/kPa or 33 – 43 mmHg) an internal air leak is possible (see *Troubleshooting*). Replace the single-use, disposable moisture trap and perform the calibration procedure. If the problem persists, contact Nonin Technical Service.

In order to prevent damage to the equipment, always charge the battery to full capacity before storing the monitor.

Avoid rapid temperature change or extreme temperatures. This can cause malfunction.

Never store or transport the monitor where condensation can occur. If condensation does occur, wait until all condensation has evaporated before using the monitor.

















## **⚠ Cautions (Continued)**

The temperature of the monitor may exceed 41 °C, but will not exceed 49 °C when operating at high ambient temperatures (40 °C). Limit skin contact to less than 1 minute and inspect the contact area often. Patient sensitivity may vary due to medical status or skin condition.
Do not attempt to replace the battery inside the monitor. The battery is not field replaceable and cannot be replaced by the operator. Use only Nonin-specified components. Use of another battery may present a risk of fire or explosion. Contact Nonin Technical Service when the battery needs replacing. Battery replacement by inadequately trained personnel could result in a hazardous situation.
Do not charge Li-Ion batteries at a temperature of 0 °C (32 °F) or less as this may result in significantly reduced battery life.
Do not use the power supply if the integrity of the AC cord conductors or the outlet is in doubt.
This device is a precision electronic instrument and must be repaired by Nonin Technical Service. Field repair of the device is not possible. Do not attempt to open the case or repair the electronics. Opening the case may damage the device and void the warranty.
In compliance with the European Directive on Waste Electrical and Electronic Equipment (WEEE) 2002/96/EC, do not dispose of this product as unsorted municipal waste. This device contains WEEE materials; please contact your distributor regarding take back or recycling of the device. If you are unsure how to reach your distributor, please call Nonin for your distributor's contact information.
When using the monitor in the home, avoid exposing the monitor to lint and dust.
When using the monitor around small children and pets, avoid leaving the monitor unattended. Cables and cannulas pose a risk of injury, including strangulation. Small items (e.g., filter) are choking hazards.
Be careful not to drop the monitor on the floor or strike it against hard surfaces. If such an incident happens, do not use the monitor until a functional test has been performed.
The monitor is equipped with automatic barometric pressure compensation. End tidal pCO <sub>2</sub> values displayed are calculated based on an atmospheric pressure of 760 mmHg and pH <sub>2</sub> O of 47 mmHg (example: 760 – 47 = 713, 713 x 5% = 36 mmHg).
This monitor is equipped with isolation and protects the patient against burns when used with high-frequency surgical equipment.
Water or other liquid in the sample line may cause erroneous EtCO <sub>2</sub> readings or an occlusion.
Ensure that all connections are tight, leak-free, and properly attached.
If the Nafion tubing becomes contaminated or damaged during use, discard it and replace it with a new one.
Portable and mobile RF communications equipment can affect medical electrical equipment.
Field strengths from fixed transmitters, such as base stations for radio (cellular/cordless) telephones and land mobile radios, amateur radio, AM and FM radio broadcast towers and TV broadcast towers may affect accuracy.
This equipment complies with IEC 60601-1-2 for electromagnetic compatibility for medical electrical equipment and/or systems. This standard is designed to provide reasonable protection against harmful interference in a typical medical installation. However, because of the proliferation of radio-frequency transmitting equipment and other sources of electrical noise in healthcare and other environments, it is possible that high levels of such interference due to close proximity or strength of a source might disrupt the performance of this device. Medical electrical equipment needs special precautions regarding EMC, and all equipment must be installed and put into service according to the EMC information specified in this manual.
All parts and accessories connected to the USB port of this device must be certified according to at least IEC Standard EN 60950, IEC 62368-1, or UL 1950 for data-processing equipment.
Failure of a network data coupling (USB cable/connectors) will result in loss of data transfer.
If the entire memory is filled, portions of the oldest record will be overwritten when new data is written.









## Guide to Symbols

This chapter describes the symbols that are found on the system components and packaging.

**Table 1. Symbols**

Symbol	Description/Function
	CAUTION!
	Follow Instructions for Use.
	CE Marking indicating conformance to EC Directive No. 93/42/EEC concerning medical devices.
	Authorized representative in the European Community.
	Indicates separate collection for electrical and electronic equipment (WEEE).
	Class II, double insulated
	UL Mark for Canada and the United States with respect to electric shock, fire, and mechanical hazards only in accordance with: <ul style="list-style-type: none"> <li>ANSI/AAMI ES60601-1:2005/(R)2012 and CAN/CSA-C22.2 No. 60601-1:14</li> <li>ISO 80601-2-61:2011, IEC 60601-2-49:2011, IEC 60601-2-55:2011, IEC 60601-1-8: 2006+A1:2012</li> </ul>
	Defibrillation-Proof Type BF-Applied Part (patient isolation from electrical shock). Defibrillator-proof isolation is implemented into the device, so any sensor connected to the device is protected.
<b>IP22</b>	Protected against vertically falling water drops when enclosure is tilted up to 15 degrees and against access to hazardous parts with a finger per IEC 60529.
	Green charging indicator (LED)
	On/Standby button
	Audio Pause button
	Power supply input
	USB port
	Luer lock connector for sample line, Nafion tubing, or cannula
	Do not reuse (moisture trap)

**Table 1. Symbols (Continued)**

Symbol	Description/Function
	Federal law (USA) restricts this device to sale by or on the order of a licensed practitioner.
	Manufacturer
	Catalogue number
	Serial number
	Quantity
	Temperature limitation for storage/shipping
	RoHS compliant (China)
	Date of manufacture
	Country of manufacture

## Introduction

Each operator should read this manual before using the monitor.

### ***About RespSense II***

RespSense II allows healthcare professionals to non-invasively monitor capnometry on either intubated or spontaneously breathing patients.

When measuring EtCO<sub>2</sub>, the patient is attached to the monitor by a sample line that can be an airway adapter for an endotracheal tube, a nasal cannula, or a nasal cannula with supplemental oxygen delivery. A variety of sample lines can be used and connected to a specially designed moisture trap, which is easily snapped into the monitor. The sample lines can be used with or without Nafion<sup>®</sup> tubing. Use only those accessories recommended by Nonin. Refer to the *Accessories* section for more information.

The monitor has a touch screen display where settings and adjustments are made. The only buttons on the monitor, On/Standby (off) and Audio Pause, are located on the upper right corner of the front panel. Next to these buttons there is a small indicator that turns green when the monitor is connected to a power outlet. The monitor operates on a fully-charged battery for approximately 5 hours.

### ***About Capnometry***

The monitor uses sidestream non-dispersive infrared (NDIR) spectroscopy to continuously measure the amount of CO<sub>2</sub> present at the end of exhalation (EtCO<sub>2</sub>), and respiratory rate (RR). Capnometry has been proven to be a reliable method for detecting esophageal intubation, hypoventilation, and disengagement of the endotracheal tube during mechanical ventilation.



**CAUTION:** When using sample lines that also deliver oxygen to the patient, it is important to be aware that the EtCO<sub>2</sub> value may be diluted when used in combination with supplemental oxygen. To obtain a true EtCO<sub>2</sub> reading, it is recommended that the supplemental oxygen be disconnected for a few seconds to establish a baseline.



## System Components

Carefully remove the monitor and accessories from the shipping carton.

The standard system configuration includes these non-sterile components:

- RespSense II monitor
- Power supply and plug
- Single-use, disposable moisture trap with filter
- Single-use, disposable filters (qty 3)
- Adult nasal cannula (qty 3)
- Sample line
- T-connector
- Operator's manual (CD)

See *Accessories* for information on optional accessories.

After unpacking the monitor and accessories, connect the monitor to the power supply and a power outlet and ensure the green LED charge indicator is lit.

Before using the monitor, charge it for at least 6 hours.

# RespSense II Monitor

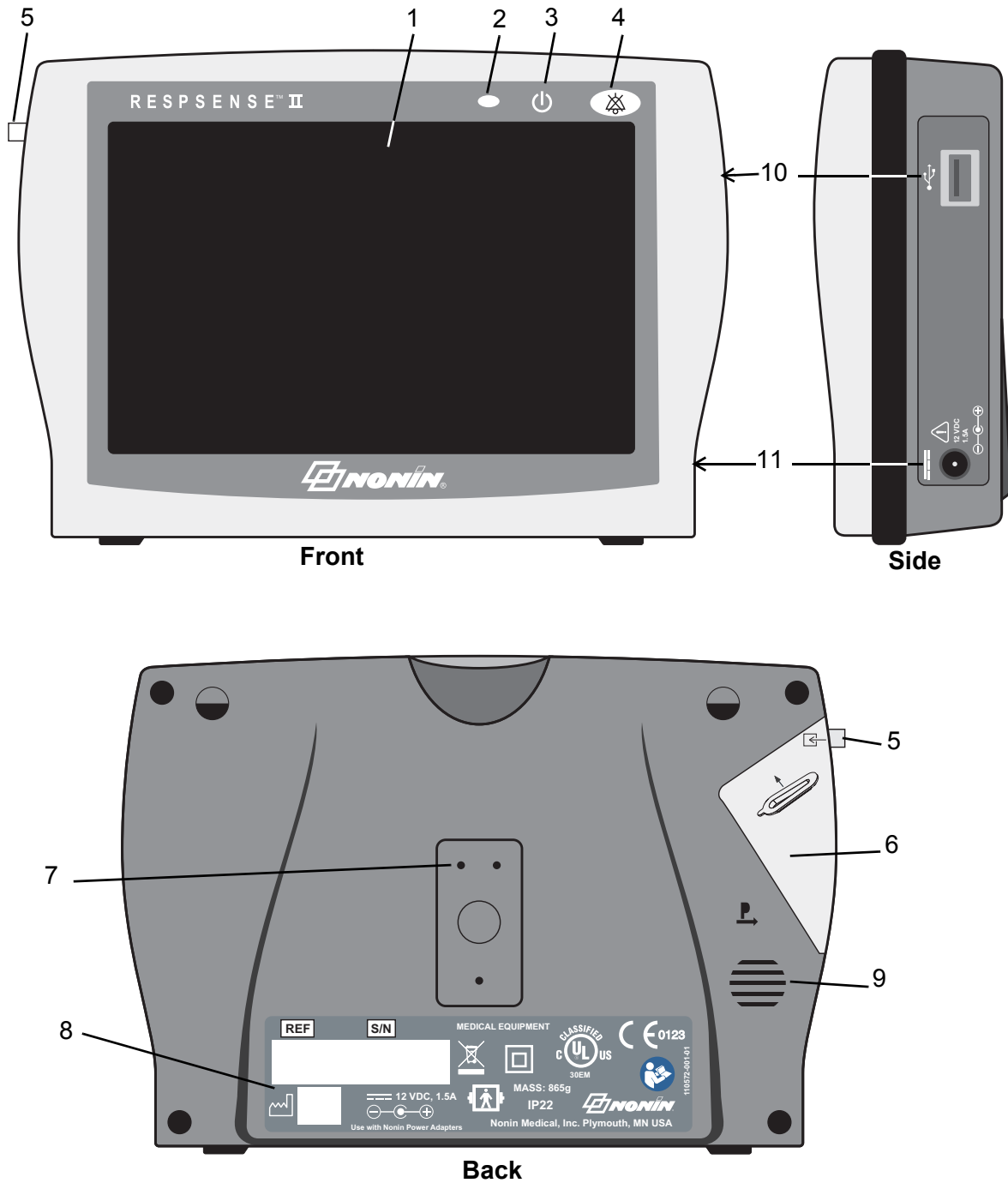

Figure 1. Monitor Features

Table 2. Monitor Features







No.	Symbol/Name	Description
1	Touch Screen Display	<p>The monitor's LCD displays parameters, graphs, menus, and other information. The display is a touch screen from which all operator-defined settings are made.</p> <p>See <i>Display Screens</i> section for additional screen information and descriptions.</p>
2		<p><b>Charging Indicator</b></p> <p>The LED indicator is green whenever the power supply is connected and the battery is charging.</p> <p><b>NOTE:</b> When the external power supply is disconnected, the device automatically switches to battery power without loss of functionality.</p>
3		<p><b>On/Standby Button</b></p> <ul style="list-style-type: none"> <li>• <b>On</b> – Pressing this button once turns on the monitor.</li> <li>• <b>Standby (off)</b> – When the monitor is on, pressing this button for at least 3 seconds shuts down the monitor, putting it into Standby mode. In Standby mode, all device functions are shut off, with the following exceptions: <ul style="list-style-type: none"> <li>• The charging indicator is lit whenever the device is plugged in.</li> <li>• Batteries are charged whenever the device is plugged in.</li> </ul> </li> </ul> <p>See <i>Shut Down Modes</i> for information about Standby and Deep Sleep modes.</p>
4		<p><b>Audio Pause Button</b></p> <p>Pressing the Audio Pause button temporarily silences audible alarms for 2 minutes. The operator can reactivate the alarms before the 2 minutes are up by pressing the button again.</p>
5		<p><b>Luer Lock Connector</b></p> <p>For attaching the sample line, Nafion tubing, or cannula.</p>
6	Moisture Trap with Filter (Single-Use, Disposable)	<p>The moisture trap and filter are single-use, disposable components and should be replaced after each patient. The filter fits into the moisture trap and protects the monitor from moisture.</p> <p>See <i>Replacing the Moisture Trap/Filter</i> for more information.</p>
7	Mounting Bracket Attachment Holes	<p>The mounting bracket is screwed onto the back of the monitor. After attaching the mounting bracket to the monitor, securely clamp the monitor to the pole. See <i>Accessories</i>.</p>
8	Label	<p>See the <i>Guide to Symbols</i> section for descriptions of the label symbols. Every device has a unique serial number for identification.</p>

Table 2. Monitor Features (Continued)

No.	Symbol/Name	Description
9		<b>Speaker</b> <b>WARNING: Ensure that all alarm volumes are audible in all situations. Do not cover or obstruct any speaker openings.</b>
10		<b>USB Port</b> Connects a USB flash drive, PSG DAC cable, or Capno RTC cable to the monitor. <b>CAUTION: All parts and accessories connected to the USB port of this device must be certified according to at least IEC Standard EN 60950, IEC 62368-1, or UL 1950 for data processing equipment.</b>
11		<b>Power Supply Input</b> Connects the power supply to the monitor. Only use Nonin-specified power supplies.

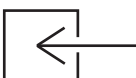
## Rechargeable Battery

The monitor is designed to operate continuously when connected to a power outlet or for approximately 5 hours on a fully-charged battery.

- A flashing yellow battery indicator (low battery) displays when the battery is almost depleted. This gives the operator approximately 60 minutes of use, or time to plug in the monitor before it switches itself off.
- A flashing red battery indicator (critical battery) displays when 10 minutes of power is left before the monitor switches itself off.

Recharging a fully-depleted battery takes approximately 9 hours when using a Nonin-specified power supply. Always connect the monitor to an outlet whenever it is not in use.

For more information, see the Internal Power section of the *System Specifications*.



**CAUTION:** Do not charge Li-Ion batteries at a temperature of 0 °C (32 °F) or less as this may result in significantly reduced battery life.

**WARNING:** To avoid patient injury, only use Nonin-specified power supplies, cables, and accessories (see *Accessories*).



## Battery Replacement

The battery, made of Lithium Ion (Li-Ion) rechargeable cells, is integral to the device and cannot be replaced by anyone other than Nonin Technical Service. The life expectancy of the battery is approximately 1 year.



**CAUTION:** Do not attempt to replace the battery inside the monitor. The battery is not field replaceable and cannot be replaced by the operator. Use only Nonin-specified components. Use of another battery may present a risk of fire or explosion. Contact Nonin Technical Service when the battery needs replacing. Battery replacement by inadequately trained personnel could result in a hazardous situation.

For optimal performance, the battery should be replaced once per year to limit the amount of Li build up if the battery is charged in a cold environment.

## Sample Line

### Intended Use

The sample line is used to measure the content of carbon dioxide in exhaled air (EtCO<sub>2</sub>). It is single-use, disposable tubing that connects to the monitor's moisture trap with a Luer lock connector. One sample line is included in the standard kit. The monitor can be fitted with several types of sample lines to best suit the patient (see *Accessories*).

The following instructions refer to the nasal cannula supplied in the standard system configuration. Other sample lines have separate instructions included in their packaging.

### Applying the Sample Line

1. Insert the cannula into the patient's nostrils.
2. Place the tubing behind each ear.
3. Connect the Luer lock fitting to the moisture trap and twist to tighten.

**WARNING:** To avoid patient injury, only use Nonin-specified power supplies, cables, and accessories (see *Accessories*).



**CAUTION:** The sample line, moisture trap, filter, and Nafion tubing are single-patient use, disposable components. Do not reuse disposable accessories. Accessories marked "single-use" must be used on one patient only and be disposed of after usage. Dispose of all components in accordance with your local, state or national regulations regarding waste management.



**CAUTION:** The patient's nasal passage may dry out if continuous monitoring is required. Check patient hourly for nasal comfort.

## Nafion Tubing

The Nafion tubing is a single-use, disposable component designed to be placed between the moisture trap and the nasal cannula or sample line to remove water vapor.

### Attaching the Nafion Tubing

1. Connect male end of the Nafion tubing to the moisture trap. Turn clockwise to tighten.
2. Connect female end of the Nafion tubing to the sample line or cannula. Turn clockwise to tighten.
3. Ensure that the Nafion tubing is firmly attached.



**CAUTION:** Water or other liquid in the sample line may cause erroneous EtCO<sub>2</sub> readings or an occlusion.



**CAUTION:** Ensure that all connections are tight, leak-free, and properly attached.



**CAUTION:** If the Nafion tubing becomes contaminated or damaged during use, discard it and replace it with a new one.

## Single-Patient Use, Disposable Moisture Trap and Filter

The moisture trap and filter are single-patient use, disposable components. During long-term monitoring of a patient, the moisture trap fills up with liquid (condensed moisture from breathing). Check the moisture trap frequently and replace when necessary.

Make sure to keep a sufficient supply of new moisture traps and filters within easy reach.

When the moisture trap is removed, guide marks (numbered 1 and 2) and arrows, are visible on the back of the monitor. These guide marks help the operator insert the moisture trap.

### Replacing the Moisture Trap/Filter



**CAUTION:** The sample line, moisture trap, filter, and Nafion tubing are single-patient use, disposable components. Do not reuse disposable accessories. Accessories marked “single-use” must be used on one patient only and be disposed of after usage. Dispose of all components in accordance with your local, state or national regulations regarding waste management.



**CAUTION:** After exposing the monitor to an environment outside of normal room temperature/humidity conditions, always replace the moisture trap and filter before each use.

1. Place the filter in the moisture trap so the silicone gasket faces up and hydrophobic material fits inside the moisture trap opening (figure 2-A).
2. Using the guide marks on the back of the monitor, align the groove at the top of the moisture trap with the ridge at the top of the trap housing on the monitor (figure 2-B).

3. The trap is tilted in top first, then bottom. Press the moisture trap into position using the tab (figure 2-C). There should be a tactile click and the moisture trap should be flush with the side and back of the monitor.
4. To remove the moisture trap and replace the filter, use the tab to pull the moisture trap away from the monitor. Remove the filter from the moisture trap. If the filter is not in the moisture trap, check to see if it is still attached to the monitor.

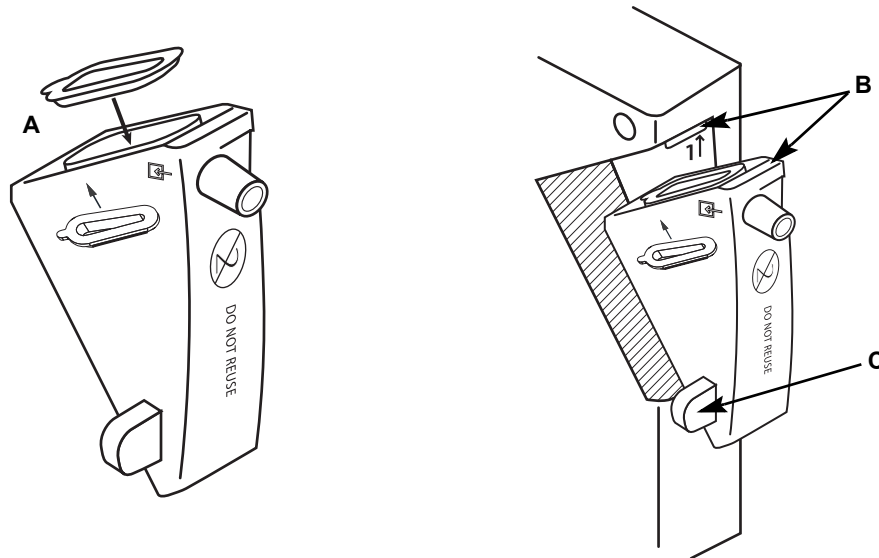

**Figure 2. Replacing the Moisture Trap/Filter**

## ***PSG DAC Cables***

Nonin's PSG DAC (Polysomnography Digital-to-Analog Converter) cables connect the monitor to a polysomnograph to record data (EtCO<sub>2</sub>, respiratory rate, SpO<sub>2</sub> and CO<sub>2</sub>).

Refer to the individual PSG DAC cable instructions for use for more information.

## ***Capno RTC Cable***

Nonin's Capno RTC digital USB cable transmits real-time data from the monitor to another device (e.g., computer).

Refer to the Capno RTC instructions for use for more information.

## Display Screens

The following section describes the icons and their functions on the select alarm group and operating screens.

### Select Alarm Group Screen

**NOTE:** This screen does not display if the monitor has locked alarm limits (see *Alarm Lock Mode Screen* section).

The select alarm group screen (figure 3) displays after the start-up screen. On this screen, the operator may select alarm limits for a patient under 30 kg, over 30 kg, or select the last used alarm settings.

If a selection is not made within approximately 8 seconds, the monitor defaults to the over 30 kg alarm limits.



Figure 3. Select Alarm Group Screen

**Table 3. Select Alarm Group Screen – Display Descriptions**

No.	Description
1	<p><b>Alarm Limits ≤30kg / 66lbs</b></p> <p>Pressing this icon selects the default alarm limits for patients weighing 30 kg (66 lbs) or less.</p> <ul style="list-style-type: none"> <li>• If the Responsible Organization Settings have not been set, the alarm limits will be the factory default settings (see table 5).</li> <li>• If the Responsible Organization Settings are set, the alarm limits may be restricted by the Responsible Organization alarm limits.</li> </ul>
2	<p><b>Alarm Limits &gt;30kg / 66lbs</b></p> <p>Pressing this icon selects the default alarm limits for patients weighing more than 30 kg (66 lbs).</p> <ul style="list-style-type: none"> <li>• If the Responsible Organization Settings have not been set, the alarm limits will be the factory default settings (see table 5).</li> <li>• If the Responsible Organization Settings are set, the alarm limits may be restricted by the Responsible Organization alarm limits.</li> </ul>
3	<p><b>Last Used Alarm Setting</b></p> <p>Pressing this button selects the last used alarm settings and alarm volume.</p>

## Operating Screen

The main operating screen (figure 4) displays parameters, graphs, and other information.

**NOTE:** If a pop-up window displays while monitoring, the icons and alarm limit up/down arrows cannot be used until the pop-up window is closed.

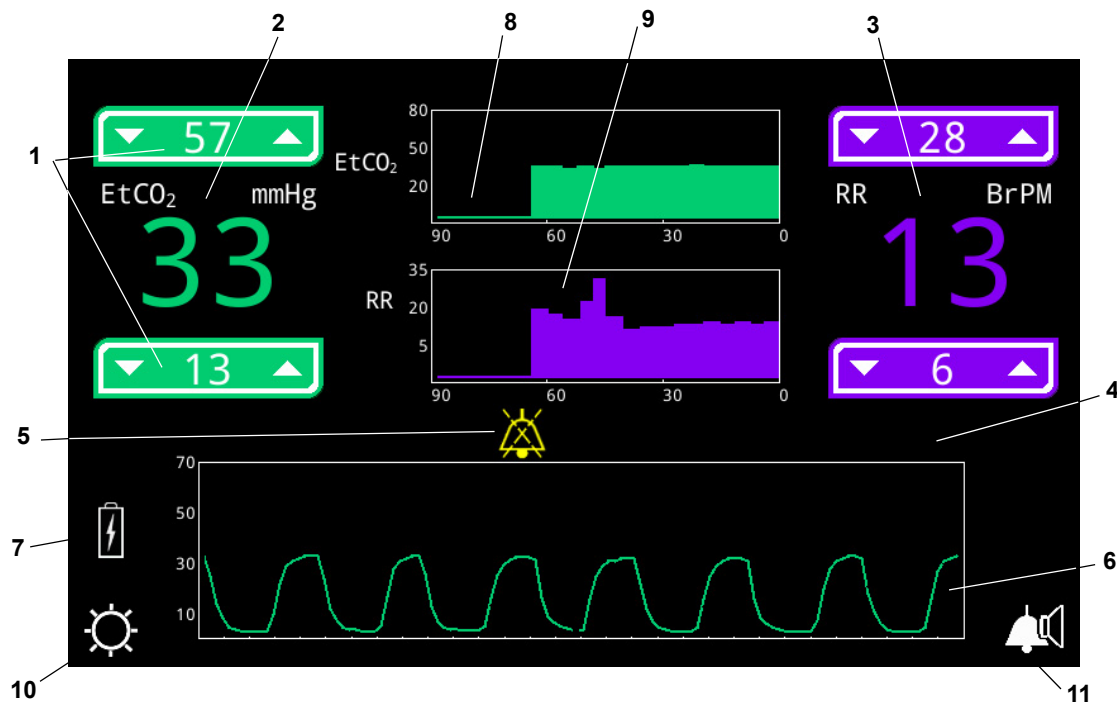



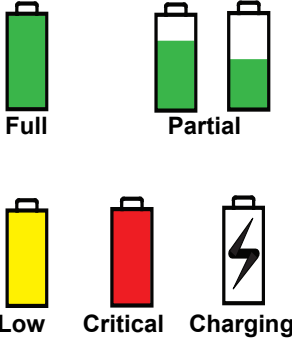

Figure 4. Operating Screen





Table 4. Operating Screen – Display Descriptions

No.	Symbol/Name	Description
1		<p><b>Alarm Limits</b></p> <p>The high alarm limit is always located above the displayed value, and the low alarm limit is always located below the displayed value.</p> <p>When the parameter readings fall between the low and high settings, they are treated as normal values. Values outside these limits activate both audible and visual alarms. The limit that triggered the alarm flashes on the display.</p> <p>See <i>Alarm Limits</i> for more information.</p>
2	<p><b>EtCO<sub>2</sub> mmHg</b> or <b>EtCO<sub>2</sub> kPa</b></p>	<p>Displays the volume of end tidal CO<sub>2</sub> in exhaled air. EtCO<sub>2</sub> is shown as mmHg or kPa.</p>

**Table 4. Operating Screen – Display Descriptions (Continued)**

No.	Symbol/Name	Description
3	<b>RR BrPM</b>	Displays the respiration rate in breaths per minute.
4	EtCO <sub>2</sub> Messages Example: 	Shows capnometer alarm messages. See <i>Alarms</i> for more information.
5		<p><b>Audible Alarm</b></p> <p>No symbol means audible alarms are enabled.</p> <p>A bell with dashed lines indicates that audible alarms are paused.</p> <p>A bell with solid lines indicates that audible alarms are off.</p>
6	Respiration Capnogram	Displays a graph of the respiration and EtCO <sub>2</sub> .
7		<p><b>Battery</b></p> <p>The battery indicator shows the approximate percentage of battery life remaining.</p> <ul style="list-style-type: none"> <li>• <b>Full/Partial</b> – Battery indicator is green.</li> <li>• <b>Low</b> – Battery indicator flashes yellow.</li> <li>• <b>Critical</b> – Battery indicator flashes red.</li> <li>• <b>Charging</b> – Battery indicator displays a lightning bolt when the monitor is connected to the power supply and a power outlet.</li> </ul> <p><b>NOTE:</b> When the monitor reaches a low or critical battery condition, an audible alarm sounds if the audible alarm is on. To clear the alarm, connect the monitor to the power supply and a power outlet.</p>
8	EtCO <sub>2</sub> Trend Graph	Scale is 20 – 80 mmHg (2.7 – 10.7 kPa). This scale is fixed and cannot be changed.
9	RR Trend Graph	Scale is 5 – 35 BrPM. This scale is fixed and cannot be changed.

**Table 4. Operating Screen – Display Descriptions (Continued)**

No.	Symbol/Name	Description
10		<p><b>Brightness</b></p> <p>Pressing this icon allows the operator to change the brightness of the display while monitoring. Options are maximum (default), medium, and low.</p>
11	 Medium  Maximum (default)  Off	<p><b>Audible Alarm Volume</b></p> <p>Pressing this icon allows the operator to change the audible alarm volume while monitoring. The minimum alarm value is set on the Responsible Organization Settings screen.</p> <p>To set the volume to Off, the operator must press <b>OK</b> in the “Audible Alarms Off” pop-up window. The audible alarm may only be shut off if allowed by the Responsible Organization Settings.</p> <p><b>NOTES:</b></p> <ul style="list-style-type: none"> <li>• Configure the alarm volume options using the Responsible Organization Settings screen (see the <i>Minimum Alarm Volume</i> and <i>Default Alarm Volume</i> sections).</li> <li>• Audible alarms cannot be shut off if the Minimum Alarm Volume field is set to Medium or Maximum.</li> <li>• The default alarm volume is either the saved Default Alarm Volume or the last used volume (if Last Used Alarm Setting is selected at start-up).</li> </ul>



## Using the RespSense II Monitor

Before use, ensure the battery is fully charged by viewing the battery indicator on the display.



**CAUTION:** To ensure the longevity and safety of the monitor, the carrying case must be used when operating the monitor in an emergency medical services (EMS) environment.



**CAUTION:** To prevent damage to the monitor, operate and store the monitor in an upright position.

### Start-up Sequence

Each time the monitor is turned on, it performs a brief start-up sequence.

1. Press and hold **On/Standby** until the LCD lights up and displays “Please Wait....” An audible beep sounds while holding the button.
2. A second audible beep (speaker test) sounds when the Nonin logo start-up screen (figure 5) displays. The lower left corner of the screen shows the monitor’s software revision.

Verify each of the above items occur on initialization. If any do not occur, contact Nonin Technical Service for assistance.

If the clock is not set, the message “System Time is Not Set” displays above the software revision.

If the warning “Settings File CRC Error, Restoring Factory Default Settings” pop-up displays, all settings but the clock revert back to the factory defaults.

If the “Calibration Due” pop-up displays, press **OK** to continue or allow the message to time out (5 seconds). This message will display during start-up until the monitor is calibrated.

**NOTE:** The Responsible Organization Settings screen is accessed through the start-up screen. See the *Responsible Organization Settings Screen* section for more information.



**Figure 5. Start-up Screen**

### Shut Down Modes

To conserve battery life, the monitor has two shut down modes – Standby mode and Deep Sleep mode. Start-up from Standby mode is slightly faster than start-up from Deep Sleep mode.

#### Standby Mode

The monitor enters Standby mode if the battery indicator at shut down is green or if the monitor is connected to a power supply.

## Deep Sleep Mode

If the monitor is not plugged in and has been in Standby mode for more than an hour, it enters Deep Sleep mode.

The monitor immediately enters Deep Sleep mode if the battery level at shut down is either low (yellow battery indicator) or critical (red battery indicator).

## System Setup

1. Place the monitor in a position so the display can be clearly seen.
  - If using the monitor portably or in an environment without power, the monitor can operate for approximately 5 hours on a fully-charged battery. The battery indicator on the display shows the battery capacity.
  - If using the monitor while connected to the power supply and a power outlet, the green charging indicator is lit. The battery indicator on the display shows a lightning bolt to indicate the battery is charging.
2. Visually inspect the monitor and make sure it has no visible signs of damage.
3. Replace the single-use, disposable moisture trap and filter before each use. Refer to *Single-Patient Use, Disposable Moisture Trap and Filter* for instructions on how to replace the moisture trap and filter.



**CAUTION:** After exposing the monitor to an environment outside of normal room temperature/humidity conditions, always replace the moisture trap and filter before each use.

4. Connect the sample line to the connector on the moisture trap and secure it by turning the Luer lock connector clockwise. Only use sample lines recommended by Nonin (see *Accessories*).
5. See *Monitoring a Patient*.

**WARNING:** Prior to connecting the monitor to the power supply and a power outlet, be sure to verify the voltage and frequency rating on the power supply are the same as the outlet. If this is not the case, do not connect the monitor and power supply to the outlet.

**WARNING:** The monitor displays a flashing yellow battery indicator (low battery) when it has approximately 60 minutes of use remaining before it shuts itself off.

## Monitoring a Patient

1. Verify the system has been set up (see *System Setup*).
2. Attach the sample line to the patient, as described in *Applying the Sample Line*, or refer to the individual sample line instructions for use.
3. Press **On/Standby** to turn the monitor on.

**WARNING:** When turning on the monitor, verify that a beep is heard. If a beep is not heard, do not use the device. The speaker may not be functioning properly.

4. Monitor runs a self-test (see *Start-up Sequence*).
5. Select alarm limits. If alarm limits are locked, this screen does not display.

 **CAUTION:** Each time the system is turned on, audible alarms are silenced for 2 minutes unless the operator presses the Audio Pause button.

 **CAUTION:** Capnography alarms are not active until the first breath is detected.

6. Verify the graphs and alarm limits display on the touch screen display.
7. If allowed, adjust the alarm limits for the patient. Refer to *Alarm Limit Settings* for instructions on how to change alarm limits.
8. The audible alarm function activates approximately 2 minutes after start-up. The operator can activate the audible alarm before the 2 minutes are up by pressing the Audio Pause button.
9. The monitor is ready to use.

 **CAUTION:** The patient's nasal passage may dry out if continuous monitoring is required. Check patient hourly for nasal comfort.

 **CAUTION:** Set or adjust only one parameter at a time.

10. When done monitoring, press **On/Standby** for 3 seconds to turn off the monitor.
11. Disconnect the patient.

**NOTE:** If the monitor is on and the patient is no longer connected, the alarm will activate.

## Configuration Menu

The Configuration Menu allows the operator to:

- Change the display language and units of measurement (mmHg or kPa)
- Configure the Responsible Organization Settings
- Set the date and time
- Lock the alarm limits
- Calibrate the device

### Access the Configuration Menu

1. Press **On/Standby** to turn the monitor on.
2. Start-up sequence begins.
3. When the Nonin logo start-up screen displays, press the Nonin logo twice (double-tap). In figure 6, the Nonin logo is highlighted with a white box.
4. Configuration Menu (figure 7) displays.
5. After configuring the monitor, click **OK** to close the Configuration Menu and begin monitoring.

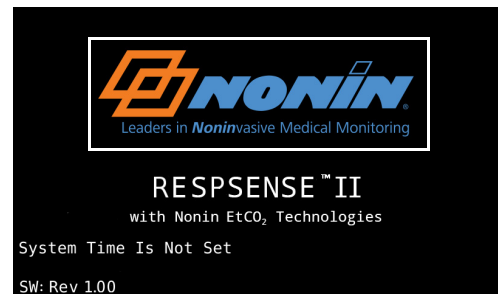

**Figure 6. Access Configuration Menu (Nonin Logo)**

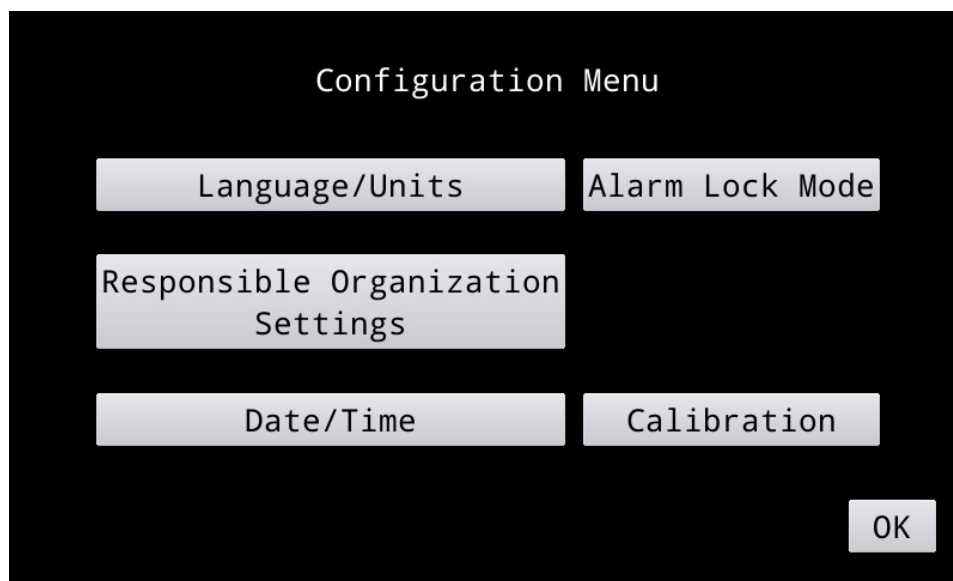

**Figure 7. Configuration Menu**

## Language/Units Screen

This screen allows the operator to change the display language and the EtCO<sub>2</sub> unit of measurement. This screen is accessed through the Configuration Menu (see *Access the Configuration Menu*). Defaults are English and mmHg.

### Set Language and/or Units of Measurement

**NOTE:** When the Units of Measurement are changed, the Responsible Organization Settings revert to the factory defaults.

1. On the Configuration Menu, press **Language/Units**. Language/Units screen (figure 8) displays.
2. Press desired language. A check mark displays to the left of the selection.
3. Press desired units of measure. A check mark displays to the left of the selection.
4. When finished, press **Save** to save the changes, close the screen, and return to the Configuration Menu. To exit without saving changes, press **Cancel**.

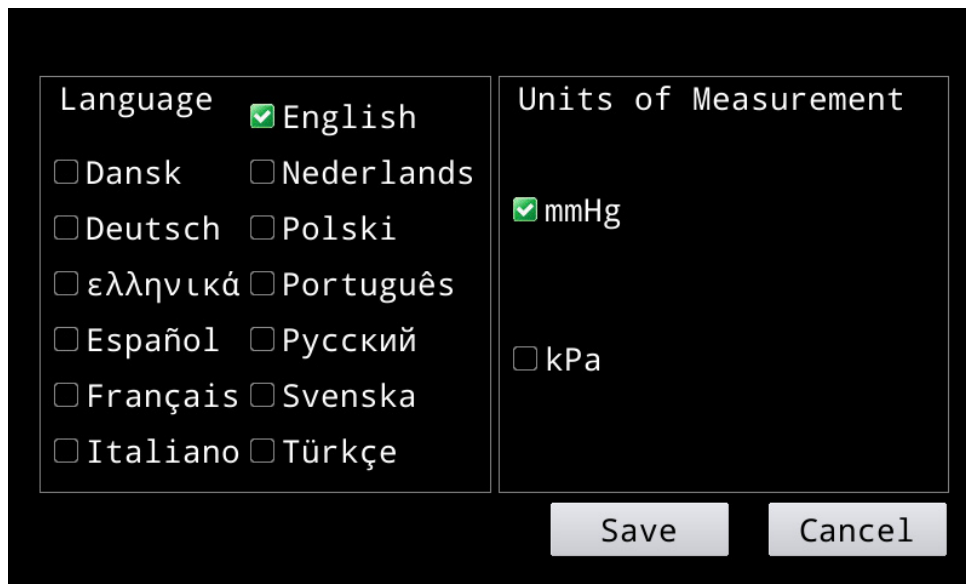

Figure 8. Language/Units Screen

## Responsible Organization Settings Screen

This screen allows the operator to establish institution default high and low limits for EtCO<sub>2</sub> and respiration rate.

This screen is accessed through the Configuration Menu (see *Access the Configuration Menu*).

### NOTES:

- The operator is required to enter a new 4-digit PIN the first time the Responsible Organization Settings screen is accessed or after restoring factory defaults.
- The Responsible Organization Settings are populated with factory default settings until changed by the organization.
- Once a PIN is saved, the alarm limits become restricted to the high and low limits on the Responsible Organization Settings screen.

1. On the Configuration Menu, press **Responsible Organization Settings**.
2. Enter the responsible organization PIN and press **OK**. Responsible Organization Settings screen displays (figure 9).
3. From this screen, the operator may:
  - Set the minimum alarm volume
  - Set the default alarm volume
  - Set the responsible organization's alarm limits: EtCO<sub>2</sub> and respiration rate (RR)
  - Reset the device to the factory defaults
  - Change the 4-digit PIN
4. Press **Save** when all changes to the Responsible Organization Settings are complete. To exit without saving changes, press **Cancel**.



Figure 9. Responsible Organization Settings Screen

## Minimum Alarm Volume

This setting controls the monitor's available audible alarm volume levels.

The default minimum alarm volume is Medium.

### *Set the Minimum Alarm Volume*

1. Access the Responsible Organization Settings screen.
2. In the Minimum Alarm Volume field, press one of the options. Options include Off, Medium (default), and Maximum. A check mark displays to the left of the selection.
  - Off – all options are available when monitoring, including shutting audible alarms off.
  - Medium – both medium and maximum alarm volumes are available when monitoring.
  - Maximum – only the maximum alarm volume is available when monitoring.

## Default Alarm Volume

The default alarm volume is Maximum.

### *Set the Default Alarm Volume*

1. Access the Responsible Organization Settings screen.
2. In the Default Alarm Volume field, press one of the volume options. Options include Medium and Maximum (default). A check mark displays to the left of the selection.

## Alarm Limits – EtCO<sub>2</sub>, RR

The alarm limit settings allow the Responsible Organization to restrict upper and lower alarm limits.

Use the up/down arrows to adjust the high and low alarm limits to the desired values.

### *Set the Responsible Organization Alarm Limits*

1. Access the Responsible Organization Settings screen.
2. In the EtCO<sub>2</sub> field, use the up/down arrows to adjust the high and low alarm limits to the desired values.
3. In the RR (respiration rate) field, use the up/down arrows to adjust the high and low alarm limits to the desired values.

## Reset Device to Factory Defaults

This setting discards all user settings and returns the monitor to the factory default settings and alarm limits.

### Restore Factory Defaults

1. Access the Responsible Organization Settings screen.
2. Press **Reset Device to Factory Defaults**.
3. In the “Factory Restore” pop-up window:
  - Press **Yes** to restore the factory defaults. The monitor:
    - Reverts to the factory default minimum alarm volume, default alarm volume, and alarm limits (see table 5).
    - Deletes the PIN.
    - Removes the Responsible Organization Settings limit restrictions.
  - Press **No** to cancel.



## New PIN

---

**NOTE:** The operator is required to enter a new 4-digit PIN the first time the Responsible Organization Settings screen is accessed or after restoring factory defaults.

---

The PIN, which may be set to any 4-digit number, is used to unlock parameter settings on the Responsible Organization Settings screen.

### Change the PIN

1. Access the Responsible Organization Settings screen.
2. Press **New PIN**.
3. In the “Enter New PIN” pop-up window, enter a 4-digit PIN.

---

**NOTE:** If the PIN is less than four digits, the “Invalid PIN Entered” pop-up window displays. Press **OK** to acknowledge and press **New PIN** again.

---

4. Press **OK** to save the new PIN. To exit without saving changes, press **Cancel**.
5. Display returns to the Responsible Organization Settings screen.



## Factory Service

This feature is only used by Nonin Medical, Inc.



## Date/Time Screen

This screen allows the operator to set the monitor's date and time (24-hour clock). The date/time is used in the file name when downloading data. If the operator will not be downloading data, setting the date/time is not required.

This screen is accessed through the Configuration Menu (see *Access the Configuration Menu*).

1. On the Configuration Menu, press **Date/Time**. Date/Time screen (figure 10) displays.
2. To select a field, press the up or down arrow for that field.
3. Tap the up arrow to increase the value; tap the down arrow to decrease the value. Steadily press the arrow to scroll through the values.
4. When finished, press **Save** to save the date and time, close the screen, and return to the Configuration Menu. To exit without saving changes, press **Cancel**.

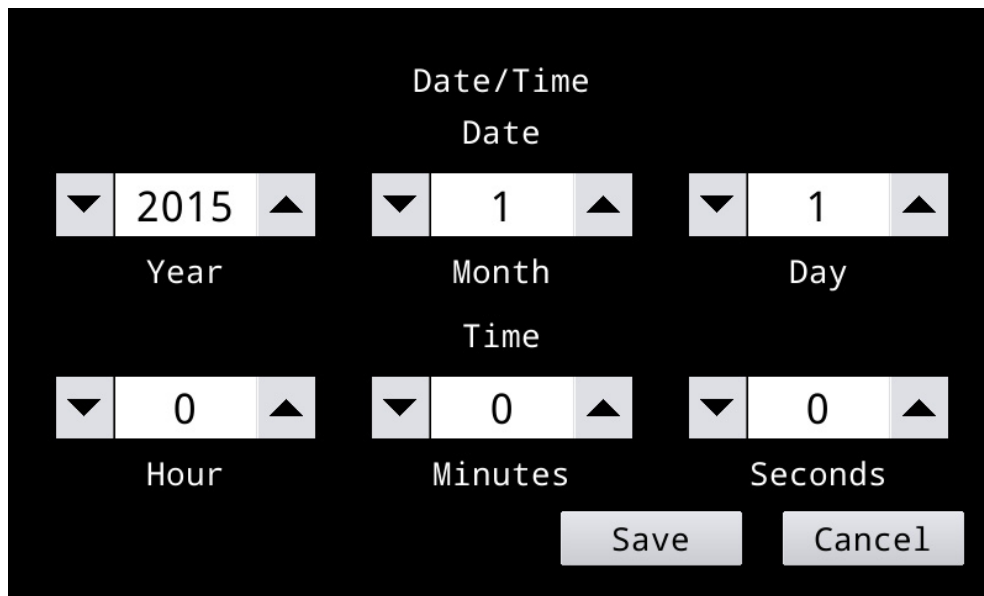

Figure 10. Date/Time Screen

---

**NOTE:** When monitoring a patient after a complete loss of battery power, the date/time recorded in new patient data files will begin counting from the date/time of the last shutdown.

---

## Alarm Lock Mode Screen

This screen allows the operator to set and lock the monitor's alarm limits.

---

**NOTES:**

- The locked alarm limits cannot be set to limits outside of the Responsible Organization limits.
  - When alarm limits are locked, limits cannot be adjusted when monitoring.
-

This screen is accessed through the Configuration Menu (see *Access the Configuration Menu*).

1. On the Configuration Menu, press **Alarm Lock Mode**. Alarm Lock Mode screen (figure 11) displays.
2. To lock the alarm limits, press **On**. A check mark displays to the left of the selection.
3. Use each parameter's up/down arrows to adjust the high and low alarm limits.
4. When finished, press **Save** to save the changes, close the screen, and return to the Configuration Menu. To exit without saving changes, press **Cancel**.

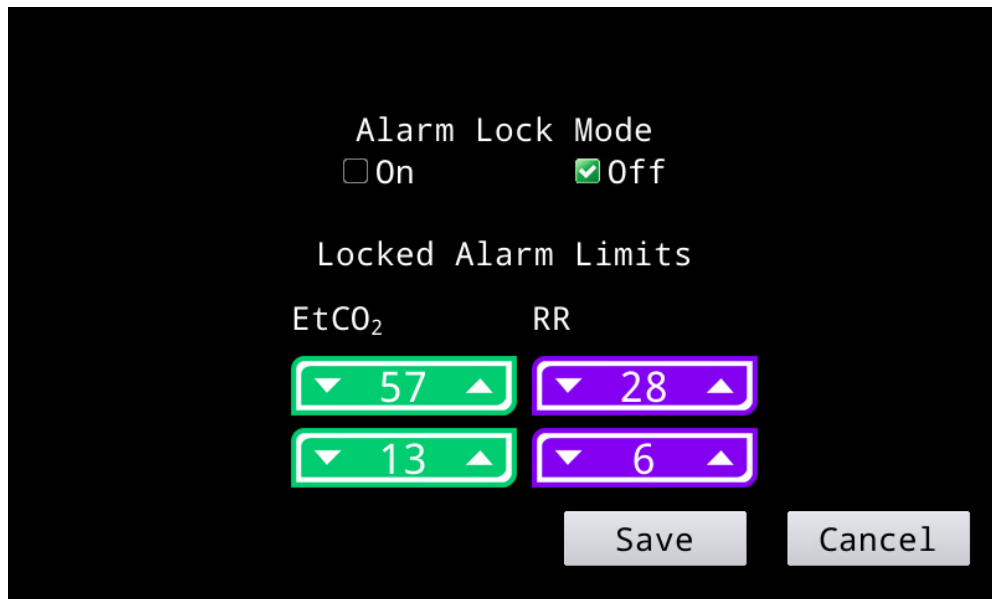

**Figure 11. Alarm Lock Mode Screen**

## ***Calibration Screen***

This screen is accessed through the Configuration Menu (see *Access the Configuration Menu*).

### **Calibration Procedure**

The monitor has a built-in zero-point calibration function for CO<sub>2</sub>. Perform the calibration procedure at least every 6 months, or if the baseline of the CO<sub>2</sub> graph is elevated.

The calibration apparatus (see *Accessories*) is reusable for approximately 100 times. When the pellets start to turn purple they cannot absorb any more CO<sub>2</sub> and the calibration apparatus must be replaced. Dispose of the calibration apparatus in accordance with your local, state, or national regulations concerning waste materials.

1. Attach a calibration apparatus to the moisture trap.
2. Press **On/Standby** to turn on the monitor.
3. Access the Configuration Menu.
4. Press **Calibration**. Calibration screen (figure 12) displays.

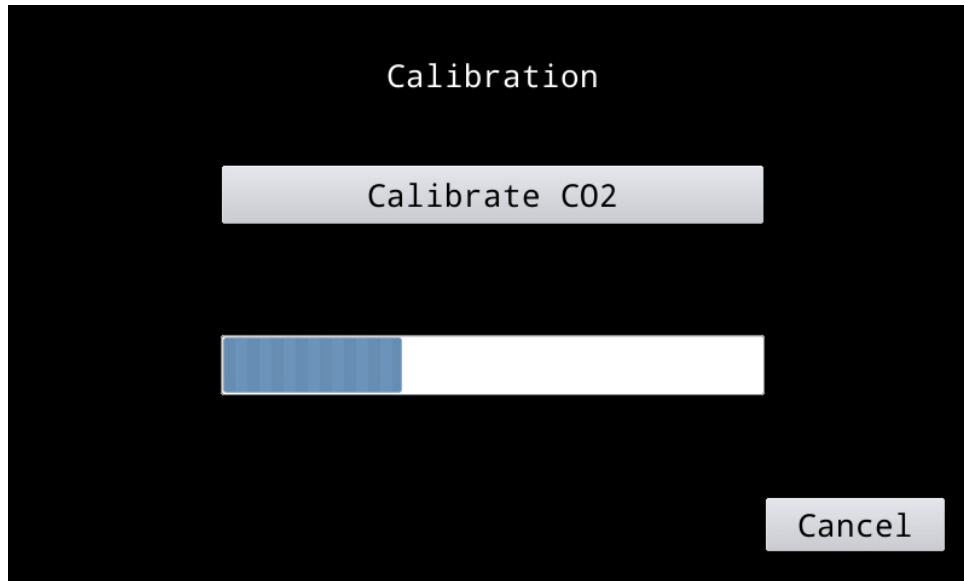

**Figure 12. Calibration Screen**



5. Press **Calibrate CO2**. The monitor starts the calibration procedure.
6. Calibration takes 15 minutes to complete. When calibration is finished, the monitor returns to the Configuration Menu.
7. Press **OK** to exit the Configuration Menu.
8. Disconnect the calibration apparatus.
9. Verify calibration:
  - a. Connect the gas valve, which is already equipped with a T-connector, to a gas bottle containing 5 Vol% of CO<sub>2</sub> (verifying gas) and the monitor.
  - b. Verify that the gas valve needle is in the green zone of the dial indicator. If the gas valve needle is in the red zone, the CO<sub>2</sub> tank is empty and should be replaced.
  - c. Release gas for 1 – 3 seconds (until the ball rises to the top of the column) and then turn off the gas valve. This equals one exhale. The ball should return to the bottom of the column when the gas valve is turned off. Repeat 2 – 3 times.
  - d. Verify the EtCO<sub>2</sub> reading on the display. A reading of 33 – 43 mmHg (4.4 – 5.7 kPa) is considered normal. This should agree with the device accuracy claims found in the *Capnography Specifications* section.



**CAUTION:** If the EtCO<sub>2</sub> value is out of normal range (4.4 – 5.7 Vol%/kPa or 33 – 43 mmHg) an internal air leak is possible. Replace the single-use, disposable moisture trap and perform the calibration procedure. If the problem persists, contact Nonin Technical Service.

# Alarm Limit Settings

If not locked, the operator can increase or decrease the alarm limit settings for individual patients. The alarm limit settings may be restricted by the Responsible Organization Settings.

Press the up arrow  to increase an alarm limit and the down arrow  to decrease an alarm limit.

The high alarm limit is always located above the displayed value, and the low alarm limit is always located below the displayed value.



**CAUTION:** Set or adjust only one parameter at a time.

## Alarm Limits

During start-up, the operator can select from two different default settings or the last used alarm limits.

All parameters have built-in limits that cannot be exceeded.

**Table 5. Alarm Limit Settings**

Alarm Limit	Adjustment Options	Adjustment Increments	> 30kg / 66lbs Patient (Defaults)	≤ 30kg / 66lbs Patient (Defaults)
EtCO <sub>2</sub> high	0 – 99 mmHg (0 – 13.2 kPa)	1 mmHg (0.1 kPa)	57 mmHg (7.6 kPa)	57 mmHg (7.6 kPa)
EtCO <sub>2</sub> low	0 – 99 mmHg (0 – 13.2 kPa)	1 mmHg (0.1 kPa)	13 mmHg (1.7 kPa)	13 mmHg (1.7 kPa)
RR high	3 to 60 breaths per minute (BrPM)	1 BrPM	28 BrPM	60 BrPM
RR low	3 to 60 BrPM	1 BrPM	6 BrPM	20 BrPM

**WARNING:** Verify all alarm settings and limits during system startup to ensure that they are set as intended.

**WARNING:** Before each use, it is the operator's responsibility to verify the alarm limits are appropriate for the patient being monitored.

**WARNING:** Ensure that all alarm volumes are audible in all situations. Do not cover or obstruct any speaker openings.



**CAUTION:** Setting alarm limits to extremes can render the alarm system useless.



**CAUTION:** The monitor is equipped with automatic barometric pressure compensation. End tidal pCO<sub>2</sub> values displayed are calculated based on an atmospheric pressure of 760 mmHg and pH<sub>2</sub>O of 47 mmHg (example: 760 – 47 = 713, 713 x 5% = 36 mmHg).

## Alarms

The monitor has audible and visual alarm indicators to alert the operator in case immediate patient attention is required or an equipment alarm occurs (figure 13). An audible or visual alarm remains active until the condition is no longer present. Each parameter can only have one high or low limit alarm at a time.

The Audio Pause button temporarily silences audible alarms for 2 minutes. The operator can reactivate the audible alarm before the 2 minutes are up by pressing the button again.

The intended operator's position for correctly perceiving a visual alarm signal and its priority is 1 meter (3.3 feet).

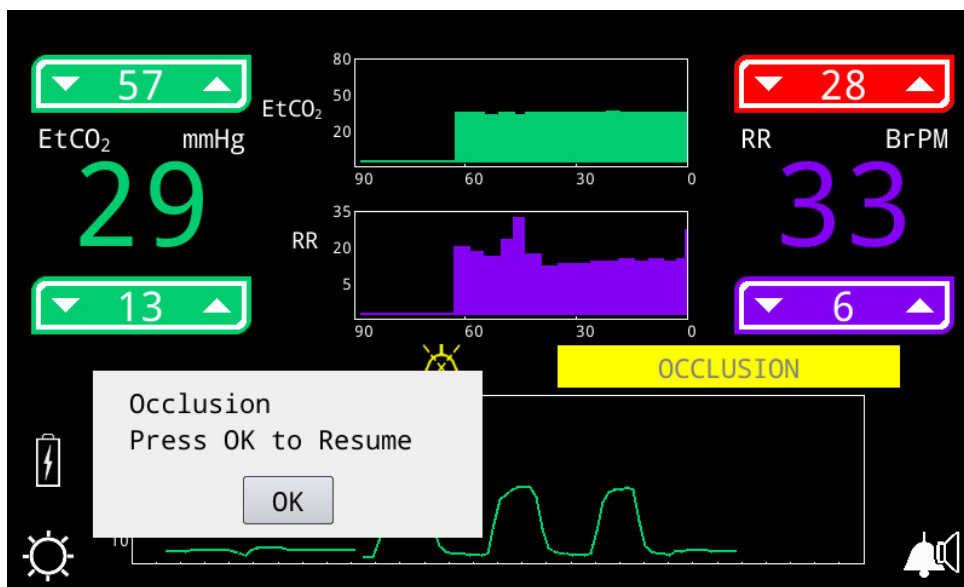

Figure 13. Operating Screen with Alarms

## High Priority Alarms

High priority alarms require immediate attention to the patient. An alarm (table 6) occurs if any of the parameters are outside the defined limits.

High priority alarms are both audible and visual.

**Table 6. High Priority Alarms**

Alarm	Visual Indicator	Audible Indicator
EtCO <sub>2</sub> High Limit – displays when EtCO <sub>2</sub> is above the high alarm limit	EtCO <sub>2</sub> high limit flashes red 2 times per second.	3 beeps, pause, 2 beeps, pause, 3 beeps, pause, 2 beeps, and a 6-second pause.  This cycle repeats until silenced or the alarm condition is cleared.
EtCO <sub>2</sub> Low Limit – displays when EtCO <sub>2</sub> is below the low alarm limit	EtCO <sub>2</sub> low limit flashes red 2 times per second.	
RR High Limit – displays when respiration rate is above the high alarm limit	RR high limit flashes red 2 times per second.	
RR Low Limit – displays when respiration rate is below the low alarm limit	RR low limit flashes red 2 times per second.	
No breath is detected for approximately 30 seconds	"NO BREATH" displays with a red background that flashes 2 times per second.	
Critical Low Battery	Battery indicator flashes red 2 times per second.	

## Medium Priority Alarms

A medium priority alarm indicates that an equipment fault has occurred and the device is unable to provide a measurement value. See table 7 for medium priority alarms.

Medium priority alarms are both audible and visual.

**Table 7. Medium Priority Alarms**

Alarm	Visual Indicator	Audible Indicator
Low battery	Battery indicator flashes yellow once every 2 seconds.	3 beeps followed by a 20-second pause.
Occlusion: <ul style="list-style-type: none"> <li>• Low or no flow from sample line or cannula</li> <li>• Clogged filter in the moisture trap</li> <li>• Kinked sample line or cannula</li> <li>• Full trap</li> </ul>	"OCCLUSION" displays with a yellow background that flashes once every 2 seconds.  To prevent damage to the pump, the pump stops after 10 seconds of occlusion and then displays a pop-up window:  "Occlusion Press OK To Resume"	This cycle repeats until silenced or the alarm condition is cleared.
Incompatible USB flash drive has been connected to the monitor.	"Incompatible USB" pop-up window displays.	

## Inoperable Alarms

Inoperable alarms (table 8) are medium priority alarms. To correct the condition, perform these steps:

1. Turn the monitor off and then back on again to remove the error message.
2. If the error persists, note the error code and contact Nonin Technical Service at (800) 356-8874 (USA and Canada), +1 (763) 553-9968, or +31 (0)13 - 79 99 040 (Europe).

**Table 8. Inoperable Alarms**

Message/Error Code	Probable Cause
NO CAPNO E04	No communication from capnography unit.
SPEAKER FAULT E05	Speaker is not working properly.
SYSTEM FAILURE E06	General system error.
BUTTON FAILURE E07	Audio Pause button is damaged.
MEMORY CORRUPT E08	Error detected in memory structure.

# Data Output and Software

## Device Memory

The monitor can collect and store a minimum of 36 hours of patient data, including 8 hours of waveform. To store data in memory, the monitoring duration must be at least 2 minutes.

Data may be downloaded from the monitor using a USB flash drive. Memory may be cleared once data is downloaded.

Patient data are sampled every second.

- EtCO<sub>2</sub> values are stored in 1 mmHg (0.1 kPa) increments in the range of 0 – 99 mmHg (0 – 13.2 kPa).
- Respiration rate values are stored in 1 BrPM increments in the range of 0 – 99 BrPM.

Patient data are retained even when both external and battery power are lost.

The memory in the device functions much like an “endless loop” tape. When the memory is full, the monitor begins overwriting the oldest data with new data.



**CAUTION:** If the entire memory is filled, portions of the oldest record will be overwritten when new data is written.

## Download Patient Data

### USB Drive Requirements

- Formatted with FAT32 file system
- Compatible with USB 2.0 or 2.1
- More than 1 GB available space
- 100 mA maximum current draw

### Recommended SanDisk<sup>®</sup> USB Flash Drives

Nonin has tested these flash drives with the monitor:

Name	Size	SanDisk P/N
Cruzer Glide™	8 GB	SDCZ60-008G-A46 (see <i>Accessories</i> section)
Cruzer Edge™	8 GB	SDCZ51-008G-A11
Cruzer Force™	8 GB	SDCZ71-008G-A46
Cruzer Blade™	4 GB	SDCZ50-004G-A46

**NOTE:** If USB flash drive performance issues occur, see the *Troubleshooting* section for more information before contacting Nonin. Nonin cannot guarantee USB flash drive performance if a recommended flash drive is not used.



## Download Data from the Monitor

**NOTE:** Data cannot be downloaded if there is a medium or high priority alarm.

1. With the monitor on, but not connected to a patient, connect a USB flash drive to the monitor.
2. In the “USB Flash Drive Detected” pop-up window, *Download Memory?* displays.
3. Press **OK** to download data. Press Cancel to return to the operating screen.
4. Once the data download is complete, the “Download Memory Complete” pop-up window displays. See *Clear Memory*.

If the USB drive is disconnected during the download, the “USB Drive Failure” pop-up displays.

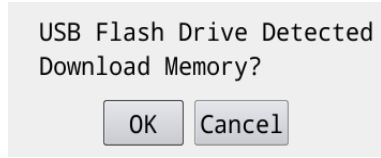

USB Flash Drive Detected  
Download Memory?

OK Cancel

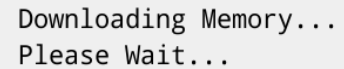

Downloading Memory...  
Please Wait...

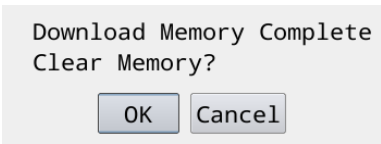

Download Memory Complete  
Clear Memory?

OK Cancel

## Clear Memory

This procedure deletes patient data recordings from the monitor.

1. In the “Download Memory Complete” pop-up window, *Clear Memory?* displays.
2. Press **OK** to clear memory.
3. In the “Clear Memory” pop-up window, *Are you sure?* displays.
4. Press **Yes**.
5. *Memory Cleared* displays.
6. Press **OK** and remove USB flash drive.
7. Operating screen displays.

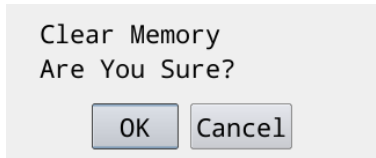

Clear Memory  
Are You Sure?

OK Cancel

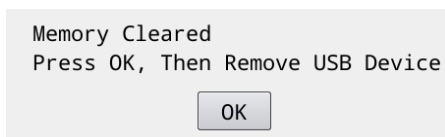

Memory Cleared  
Press OK, Then Remove USB Device

OK

## Data Format

The download directory name is the monitor's serial number (XXXXXXXXXX) followed by the current date and time.

**Example:** XXXXXXXXXX\_YYYY\_MM\_dd\_hh\_mm\_ss

**NOTE:** If the correct date/time does not display, see *Date/Time Screen* for more information on setting the clock.

Within the directory, patient data records are downloaded using a comma separated values (.csv) format. The file names are automatically generated using the record number (XXXX), the start date and time of the record, and the data type (zz).

**Example:** XXXX\_YYYY\_MM\_DD\_hh\_mm\_ss\_zz.csv

The data type (“\_zz” in example) options are \_gd (patient readings, alarm limits, and volume) and \_cw (capnography waveform data). The \_pt file contains placeholder values and is not used with RespSense II.

**NOTE:** The patient data and capnography waveform data files are read and displayed using the Capno Report Converter software (see *Accessories*).

	A	B	C	D	E	F	G	H	I	J	K	L	M	N	O	P	Q	R	S
1	Date	Time	SpO2	PR	EtCO2 (mmHg)	RR	PulseOx_Stat	Capno_Stat	Sys_Status	LAL_SpO2	UAL_SpO2	LAL_PR	UAL_PR	LAL_ETCO2	UAL_ETCO2	LAL_RR	UAL_RR	Alarm_Volume	CRC
2	8/17/2015	10:20:37	127	511	12	10	2048	0	0	0	255	0	255	13	57	6	28	Medium	46865
3	8/17/2015	10:20:38	127	511	12	10	2048	0	0										30908
4	8/17/2015	10:20:39	127	511	12	10	2048	0	0										34906
5	8/17/2015	10:20:40	127	511	12	10	2048	0	0										45110

**Figure 14. Sample Patient Data (\_gd.csv File)**

**NOTE:** In the \_gd.csv file, the SpO2, PR, PulseOx\_Status, LAL\_SpO2, UAL\_SpO2, LAL\_PR, and UAL\_PR columns contain placeholder values and are not used with RespSense II.

	A	B	C	D
1	Date	Time	CO2	CRC
2	8/17/2015	20:37.0	5	57309
3	8/17/2015	20:37.2	3	43556
4	8/17/2015	20:37.5	4	17011
5	8/17/2015	20:37.7	3	4783
6	8/17/2015	20:38.0	3	65426
7	8/17/2015	20:38.2	3	29152
8	8/17/2015	20:38.5	3	34275
9	8/17/2015	20:38.8	3	49119
10	8/17/2015	20:39.0	2	13810
11	8/17/2015	20:39.2	3	39084
12	8/17/2015	20:39.5	8	13718
13	8/17/2015	20:39.7	9	38602
14	8/17/2015	20:39.9	7	59834
15	8/17/2015	20:40.2	7	59793
16	8/17/2015	20:40.2	5	63815
17	8/17/2015	20:40.5	4	60059
18	8/17/2015	20:40.7	4	52920
19	8/17/2015	20:41.0	4	27067

**Figure 15. Sample Capnography Waveform Data (\_cw.csv File)**

Date: month, day, year

Time:

Hours, minutes, seconds (\_gd.csv files)

Hours, minutes, seconds, 1/10 second (\_cw.csv files if using “hh:mm:ss:0” custom cell format)

EtCO<sub>2</sub> and RR are the current values (\_gd.csv files). CO<sub>2</sub> is the current value (\_cw.csv files). Blank if data is missing [dashes on display].

## Capno\_Status and Sys\_Status Bits:

Bit	Capno_Status Description
23	Reserved
22	Reserved
21	Reserved
20	Reserved
19	Reserved
18	Reserved
17	Reserved
16	No CO <sub>2</sub>
15	Reserved
14	Reserved
13	Reserved
12	Reserved
11	Occlusion – Pump Off
10	Reserved
9	No Breath Alarm
8	Occlusion
7	EtCO <sub>2</sub> High Alarm Active
6	EtCO <sub>2</sub> Low Alarm Active
5	RR High Alarm Active
4	RR Low Alarm Active
3	Reserved
2	Reserved
1	Reserved
0	Reserved

Bit	Sys_Status Description
7	Alarm Silence
6	Low Batt
5	Reserved
4	Reserved
3	Reserved
2	Reserved
1	Reserved
0	Reserved

UAL is the current upper alarm limit value for each parameter.

LAL is the current lower alarm limit value for each parameter.

Alarm volume is Off, Medium or Maximum.

CRC is a 16-bit CCITT for the entire row.

## Monitor Software

Visit [nonin.com](http://nonin.com) for more information about the monitor's software, including the latest monitor software revision.

## Connecting the Device into a Medical System

Incorporating the device into a medical system requires the integrator to identify, analyze, and evaluate the risks to patient, operators, and third parties. Subsequent changes to the medical system after device integration could introduce new risks and will require additional analysis. Changes to the medical system that must be evaluated include:

- Changing the system configuration
- Adding devices to or disconnecting devices from the system
- Updating or upgrading equipment connected to the system

Issues resulting from user-initiated system changes may include corruption or loss of data.

---

### NOTES:

- Use of a multiple-socket outlet with multiple devices results in a Medical Electrical System.
- When using the USB port to connect the device to other equipment, follow each device's cleaning instructions.
- Verify all equipment connected to the device is suitable for the patient's environment.



**CAUTION:** Failure of a network data coupling (USB cable/connectors) will result in loss of data transfer.

# Maintenance and Inspection

## Maintenance

### Ensuring Optimal Performance

In order to ensure safety and optimal performance of the monitor, Nonin recommends a yearly inspection and functional check be performed on the monitor (see *Recommended Inspections and Functional Check*). The inspection and functional check may be performed by Nonin Technical Services or at your facility.

Perform the calibration procedure at least every 6 months, or if the baseline of the CO<sub>2</sub> graph is elevated (see *Calibration Procedure*). After calibration, the monitor should be verified using 5% CO<sub>2</sub> gas. The calibration apparatus, gas valve, and 5% CO<sub>2</sub> verification gas are available from Nonin (see *Accessories*).

Please contact Nonin Technical Service if monitor maintenance cannot be performed at your facility.

### Cleaning the Monitor

1. Clean the monitor with a soft cloth moistened with isopropyl alcohol. Do not use any cleaning solution other than what is recommended here, as permanent damage could result.
2. Dry with a soft cloth, or allow to air dry.



**CAUTION:** Always turn off the monitor prior to cleaning the monitor. Do not place the device in liquid or clean it with agents containing ammonium chloride or bleach. Do not sterilize or autoclave the monitor or accessories.

## Recommended Inspections and Functional Check

1. Before each use, verify the equipment is clean and in optimal operating condition. See *Cleaning the Monitor*.
2. Verify the single-use, disposable sample line or cannula is free of bends and kinks for optimal performance.
3. Verify the single-use, disposable moisture trap and filter are in position.



**CAUTION:** After exposing the monitor to an environment outside of normal room temperature/humidity conditions, always replace the moisture trap and filter before each use.

4. Visually examine the accessories for defects prior to use.
5. Press **On/Standby** to turn the monitor on.
6. Verify battery capacity. If the battery indicator is yellow or red, connect the monitor to the power supply and a power outlet.

---

**NOTE:** To ensure the monitor is always ready to use, always connect the monitor to an outlet whenever it is not in use.

---

7. Verify all parameters display correctly and, if allowed, adjust any alarm limits according to the patient.
8. Verify alarm function/status by simulating alarm situations for all parameters.
9. Visually verify the zero-point of the CO<sub>2</sub> graph is not elevated.

**WARNING: If the monitor fails to respond as described, discontinue use and contact Nonin Technical Service.**

**WARNING: Never allow liquids to enter into or to be spilled onto the monitor. If liquid has penetrated into the monitor, it must be checked by Nonin Technical Service.**



**CAUTION:** Be careful not to drop the monitor on the floor or strike it against hard surfaces. If such an incident happens, do not use the monitor until a functional test has been performed.



**CAUTION:** This device is a precision electronic instrument and must be repaired by Nonin Technical Service. Field repair of the device is not possible. Do not attempt to open the case or repair the electronics. Opening the case may damage the device and void the warranty.

# Troubleshooting

Detected fault conditions messages display on the operating screen. The fault conditions are either operator- or system-generated. The table below lists common messages, descriptions, and actions to take.

If these solutions do not correct the problem, please contact Nonin Technical Service at (800) 356-8874 (USA and Canada), +1 (763) 553-9968, or +31 (0)13 - 79 99 040 (Europe).

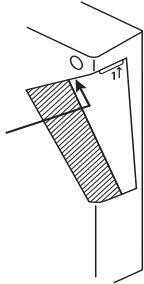
Message/Problem	Possible Cause	Possible Solution
<b>No EtCO<sub>2</sub> value or waveform displays after monitor start-up.</b>	Patient is not connected to monitor.	Verify sample line or cannula are properly connected to the patient and the moisture trap.
	Filter is incorrectly inserted into moisture trap or is missing.	Remove the moisture trap from the monitor to verify filter is properly inserted into the moisture trap.
	Moisture trap is not properly seated in the monitor.	Verify the moisture trap and filter are properly inserted in the monitor by creating an occlusion: <ol style="list-style-type: none"> <li>Using a finger, cover the Luer lock connector inlet. After 10 seconds, the pump shuts off and the "Occlusion" pop-up window displays.</li> <li>Remove the finger and press <b>OK</b> to resume.</li> <li>If there is still no value or waveform, the moisture trap is not inserted properly.</li> <li>Remove and reinsert the moisture trap in the monitor.</li> <li>Repeat occlusion test.</li> </ol>
	The monitor has an internal air leak.	Verify that there is not an internal leak to the pump by creating an occlusion: <ol style="list-style-type: none"> <li>Remove the moisture trap from the monitor.</li> <li>Using a finger, cover the small hole in the recessed area of the monitor (see arrow in figure at right).</li> <li>After 10 seconds, the pump shuts off and the "Occlusion" pop-up window displays.</li> <li>Remove the finger and press <b>OK</b> to resume.</li> <li>If there is still no value or waveform, contact Nonin Technical Service.</li> </ol> 

Message/Problem	Possible Cause	Possible Solution
<b>“OCCLUSION” displays in the EtCO<sub>2</sub> message area.</b> <b>To prevent damage to the pump, the pump stops after 10 seconds of occlusion and then displays a pop-up window:</b> <b>“Occlusion Press OK to Resume”</b>	Sample line or cannula occlusion.	Check the sample line or cannula for kinks or occlusions. Replace the sample line or cannula. Press OK to resume monitoring. If occlusion reoccurs, check filter.
	Clogged filter.	Replace the filter. Press OK to resume monitoring. If occlusion reoccurs, check moisture trap.
	Full moisture trap.	If full, replace the moisture trap.
<b>Monitor pump has shut off.</b>	Occlusion.	To prevent damage to the pump, the pump stops after 10 seconds of occlusion. See above for “OCCLUSION” message solutions. If the problem persists, contact Nonin Technical Service.
<b>Monitor has shut off.</b>	To avoid overheating, the monitor shuts off if there is an occlusion for 15 minutes.	See above for “OCCLUSION” message solutions. If the problem persists, contact Nonin Technical Service.
	The battery is depleted.	Charge the monitor. Connect the monitor to the power supply and the power supply to an outlet.
<b>“NO BREATH” displays in the EtCO<sub>2</sub> message area.</b>	The patient has stopped breathing for 30 seconds or longer.	Check the patient.
	Sample line is not properly applied to the patient.	Verify sample line placement.
	Sample line or Nafion tubing is not connected to the moisture trap.	Verify connection to moisture trap is tight.
	Moisture trap is not properly seated in the monitor.	Verify the moisture trap and filter are properly inserted in the monitor by creating an occlusion: <ol style="list-style-type: none"> <li>1. Using a finger, cover the Luer lock connector inlet. After 10 seconds, the pump shuts off and the “Occlusion” pop-up window displays.</li> <li>2. Remove the finger and press <b>OK</b> to resume.</li> <li>3. If “NO BREATH” still displays, the moisture trap is not inserted properly.</li> <li>4. Remove and reinsert the moisture trap in the monitor.</li> <li>5. Repeat occlusion test.</li> </ol>
<b>Battery indicator flashes yellow.</b>	Battery is low. Monitor will run for approximately 60 minutes.	Charge the monitor. Connect the monitor to the power supply and the power supply to an outlet. If the monitor continues to show the low or critical battery indicator after recharging, contact Nonin Technical Service as the battery may need replacement. The battery is integral to the device and cannot be replaced by the operator.
<b>Battery indicator flashes red.</b>	Battery is critically low. Monitor will shut off in 10 minutes.	



Message/Problem	Possible Cause	Possible Solution
<b>The alarm continuously sounds.</b>	The monitor is not functioning. This indicates that a problem has occurred, possibly due to interference or software issues.	Turn off the monitor and then turn on again. Charge the monitor. Connect the monitor to the power supply and the power supply to an outlet. If the problem persists, contact Nonin Technical Service.
<b>Low EtCO<sub>2</sub> alarm even though the patient's EtCO<sub>2</sub> is suspected to be normal.</b>	All alarms for low EtCO <sub>2</sub> require the operator to check the patient's status. It is also possible to get a low reading if an air leakage has occurred in the sample line, Nafion tubing, moisture trap, or internally.	Check patient status. Verify the moisture trap and filter are properly installed. Replace the moisture trap and filter if necessary. Check sample line connector and visually inspect the sample line for signs of damage. Check Nafion tubing connection. If the problem persists, contact Nonin Technical Service.
<b>An error code appears in the display area.</b>	The monitor encountered an error.	Turn the monitor off and then back on again to remove the error code. If the error persists, note the error code and contact Nonin Technical Service.
<b>Monitor will not turn on.</b>	The monitor has no power.	Plug in the power supply and verify the charging indicator is lit. If the problem persists, contact Nonin Technical Service.
<b>Monitor will not operate on battery power.</b>	The battery pack is not charged.	Charge the monitor. Connect the monitor to the power supply and the power supply to an outlet.
	The battery pack is inoperable.	Contact Nonin Technical Service.
<b>Charging indicator is not lit when the power supply is connected to the monitor and the power outlet.</b>	The system may be damaged.	Contact Nonin Technical Service.

Message/Problem	Possible Cause	Possible Solution
<b>Pressing the alarm limit up/down arrows does not adjust the alarm limits.</b>	The monitor may be in Alarm Lock Mode.	Verify display functionality by pressing the brightness icon. If the brightness changes, the alarm limits are locked.  Contact the individual responsible for configuring your organization's devices.
	The alarm limit settings may be restricted by the Responsible Organization Settings.	Access the Responsible Organization Settings screen and adjust the high and low alarm limits.  Contact the individual responsible for configuring your organization's devices.
	A pop-up window displays on the monitor screen.	Address the pop-up window and then try adjusting the alarm limits again.
	The display may not be functioning.	Verify display functionality by pressing the brightness icon. If the brightness does not change, contact Nonin Technical Service.
<b>“Incompatible USB” or “USB Device Failure” error displays.</b>	USB flash drive is full.	Delete unnecessary data from the flash drive.  or  Replace the USB flash drive with a Nonin-recommended USB flash drive.
	USB flash drive does not have enough available space.	Replace the USB flash drive with a Nonin-recommended USB flash drive.
	USB flash drive has an incorrect format.	
<b>“Settings File CRC Error” warning pop-up displays.</b>	Settings file is corrupted or missing.	System reverts to factory defaults.  Contact the individual responsible for configuring your organization's devices.
<b>“Invalid PIN Entered” pop-up message displays.</b>	When entering a new PIN, the PIN is not the correct length.	Enter a PIN that is four digits.
	The PIN entered does not match the Factory PIN or the Responsible Organization PIN.	Enter the default PIN (0000).  If 0000 is not the correct PIN, contact Nonin Technical Service.
<b>“Calibration Due” pop-up message displays during the start-up sequence.</b>	It has been 6 months since the monitor was calibrated.	Press <b>OK</b> or allow the message to time out (5 seconds). Start-up sequence continues.  Perform the <i>Calibration Procedure</i> , or contact the individual responsible for configuring your organization's devices.

## Accessories

RespSense II is designed to be used with Nonin-recommended accessories only. Use of other brands will compromise the function and performance. For more information about Nonin parts and accessories:

- Contact your distributor or Nonin at (800) 356-8874 (USA and Canada), +1 (763) 533-9968, or +31 (0)13 - 79 99 040 (Europe)
- Visit [www.nonin.com](http://www.nonin.com)

Nonin may update the accessories list at any time. It is the purchaser's responsibility to always ask for the current list, by model number, when ordering accessories.

Item	Description
<b>Power Supply</b>	Approximately 100 – 240 VAC, 50 – 60 Hz
<b>PSG DAC</b>	Digital-to-analog USB cable that connects the monitor to a polysomnograph to record data. Several versions are available; contact Nonin or your distributor for more information.
<b>Capno RTC (Real Time Cable)</b>	Digital USB cable that transmits real-time data from the monitor to another device (e.g., computer). Requires USB driver and USB port with 2.0 or greater.
<b>USB Flash Drive</b>	SanDisk Cruzer Glide™ 8 GB USB flash drive (SanDisk P/N SDCZ60-008G-A46)
<b>Capno Report Converter</b>	Software to convert LifeSense II and RespSense II data into an nVISION-compatible format.
<b>nVISION</b>	nVISION software for Microsoft Windows® operating systems
<b>Monitor Mounting Bracket</b>	Connector that enables adjustable mounting and hospital standard mounting. Delivered with 3 screws for connecting to the back of the monitor.
<b>Adjustable Mounting Clamp</b>	Allows mounting on poles. Fits on poles up to 50 mm (2.0 in.) in diameter.
<b>Carrying Case</b>	Protective carrying case in which the monitor can be fully connected without removing the bag.
<b>Nasal CO<sub>2</sub> Cannula</b>	Single-use, disposable, cannula with a male Luer lock connector. Adult (Salter Labs® Ref. 4000) Pediatric (Salter Ref. 4100) Infant (Salter Ref. 4200)
<b>Oxygen Delivery CO<sub>2</sub> Nasal Cannula</b>	Single-use, disposable O <sub>2</sub> delivery nasal cannula with male Luer lock connector. Adult (Salter Ref. 4707) Pediatric (Salter Ref. 4703) Infant (Salter Ref. 4700)
<b>CO<sub>2</sub> Sample Line</b>	Single-use, disposable, straight sample line with male Luer lock connectors on both ends (Salter Ref. 4507).
<b>Straight T-Connector</b>	Single-use, disposable gas adapter, 15 and 22 mm connector ends.
<b>Nafion Tubing</b>	Single-use, disposable Perma Pure Nafion tubing to remove water vapor from the sample line.
<b>Verification Gas</b>	Verification gas and tubing. Contains 5 Vol% of CO <sub>2</sub> (equals 38 mmHg or 5.3 kPa). To be used with a gas valve.

Item	Description
<b>Gas Valve for Verification Gas</b>	Reusable gas valve and tubing for controlling the flow from the verification gas.
<b>Calibration Apparatus</b>	Used for 0-point calibration.
<b>Moisture Trap with Filter</b>	10 packages, each containing 1 single-use, disposable moisture trap and 1 single-use, disposable filter.
<b>Filters</b>	Available in 25 or 100 pack.



## Service, Support, and Warranty

A return authorization number is required before returning any product to Nonin. To obtain this return authorization number, contact Nonin Technical Service:

**Nonin Medical, Inc.**  
13700 1st Avenue North  
Plymouth, Minnesota 55441, USA  
  
(800) 356-8874 (USA and Canada)  
+1 (763) 553-9968 (outside USA and Canada)  
Fax: +1 (763) 553-7807  
E-mail: [technicalservice@nonin.com](mailto:technicalservice@nonin.com)

**Nonin Medical B.V.**  
Prins Hendriklaan 26  
1075 BD Amsterdam, Netherlands  
  
+31 (0)13 - 79 99 040 (Europe)  
Fax: +31 (0)13 - 79 99 042  
E-mail: [technicalserviceintl@nonin.com](mailto:technicalserviceintl@nonin.com)

[nonin.com](http://nonin.com)

## Warranty

NONIN MEDICAL, INCORPORATED, (Nonin) warrants to the purchaser, for a period of 1 year from the date of purchase, each battery and touch panel display screen. Nonin warrants the RespSense II monitor for a period of 3 years from the date of purchase. Extended warranties are available on most Nonin devices. Please consult your local Nonin distributor for additional information. The device's expected service life is 5 years.

Nonin shall repair or replace any RespSense II found to be defective in accordance with this warranty, free of charge, for which Nonin has been notified by the purchaser by serial number that there is a defect, provided said notification occurs within the applicable warranty period. This warranty shall be the sole and exclusive remedy by the purchaser hereunder for any RespSense II delivered to the purchaser which is found to be defective in any manner, whether such remedies be in contract, tort, or by law.

This warranty excludes cost of delivery to and from Nonin. All repaired units shall be received by the purchaser at Nonin's place of business. Nonin reserves the right to charge a fee for a warranty repair request on any RespSense II that is found to be within specifications.

The RespSense II is a precision electronic instrument and must be repaired by knowledgeable and specially trained Nonin personnel only.

Accordingly, any sign or evidence of opening the RespSense II, field service by non-Nonin personnel, tampering, or any kind of misuse or abuse of the RespSense II, shall void the warranty in its entirety. All non-warranty work shall be done according to Nonin standard rates and charges in effect at the time of delivery to Nonin.

### **DISCLAIMER/EXCLUSIVITY OF WARRANTY:**

THE EXPRESS WARRANTIES SET FORTH IN THIS MANUAL ARE EXCLUSIVE AND NO OTHER WARRANTIES OF ANY KIND, WHETHER STATUTORY, WRITTEN, ORAL, OR IMPLIED, INCLUDING WARRANTIES OF FITNESS FOR A PARTICULAR PURPOSE OR MERCHANTABILITY, SHALL APPLY.

## Technical Information

**NOTE:** This product complies with ISO 10993-1, Biological Evaluation of Medical Devices Part 1: Evaluation and Testing.



**CAUTION:** All parts and accessories connected to the USB port of this device must be certified according to at least IEC Standard EN 60950, IEC 62368-1, or UL 1950 for data-processing equipment.



**CAUTION:** Portable and mobile RF communications equipment can affect medical electrical equipment.

## Operating Environment

The equipment must only be used in situations that meet the system's specified environmental conditions. Refer to *System Specifications* in this section.

## Storage Environment

Refer to *System Specifications* in this section for the system's specified storage conditions.



**CAUTION:** In order to prevent damage to the equipment, always charge the battery to full capacity before storing the monitor.

## Power Requirements

Power Ratings	Unit
Rated supply voltages or voltage ranges for the power supply	100 – 240 VAC 50 – 60 Hz
Input voltage from the power supply	12 VDC, 1.5 A

**WARNING:** To avoid patient injury, only use Nonin-specified power supplies, cables, and accessories (see *Accessories*).



## Manufacturer's Declaration

See the following tables for specific information regarding this device's compliance to IEC 60601-1-2.

**Table 9. Electromagnetic Emissions**

Emissions Test	Compliance	Electromagnetic Environment—Guidance
<i>This device is intended for use in the electromagnetic environment specified below. The user of this device should ensure that it is used in such an environment.</i>		
RF Emissions CISPR 11	Group 1	This device uses RF energy only for its internal function. Therefore, its RF emissions are very low and are not likely to cause any interference in nearby electronic equipment.
RF Emissions CISPR 11	Class B	This device is suitable for use in all establishments, including domestic and those directly connected to the public low-voltage power supply network that supplies buildings used for domestic purposes.
Harmonic Emissions IEC 61000-3-2	Pass	
Voltage Fluctuations/ Flicker Emissions IEC 61000-3-3	Pass	

**Table 10. Electromagnetic Immunity**

Immunity Test	IEC 60601 Test Level	Compliance Level	Electromagnetic Environment—Guidance
<i>This device is intended for use in the electromagnetic environment specified below. The user of this device should ensure that it is used in such an environment.</i>			
Electrostatic Discharge (ESD) IEC 61000-4-2	±6 kV contact ±8 kV air	±6 kV contact ±8 kV air	Floors should be wood, concrete, or ceramic tile. If floors are covered with synthetic material, the relative humidity should be at least 30%.
Electrical Fast Transient/Burst IEC 61000-4-4	± 2 kV for power supply lines ± 1 kV for input/output lines	± 2 kV for power supply lines ± 500V for input/output lines	Mains power quality should be that of a typical commercial or hospital environment.
Surge IEC 61000-4-5	± 1 kV differential mode ± 2 kV for common mode	± 1 kV differential mode ± 2 kV for common mode	Mains power quality should be that of a typical commercial or hospital environment.
Voltage dips, short interruptions, and voltage variations on power supply input lines IEC 61000-4-11	± 5% $U_T$ (>95% dip in $U_T$ ) for 0.5 cycle ± 40% $U_T$ (60% dip in $U_T$ ) for 5 cycles ± 70% $U_T$ (30% dip in $U_T$ ) for 25 cycles ± 5% $U_T$ (>95% dip in $U_T$ ) for 5 cycles	± 5% $U_T$ (>95% dip in $U_T$ ) for 0.5 cycle ± 40% $U_T$ (60% dip in $U_T$ ) for 5 cycles ± 70% $U_T$ (30% dip in $U_T$ ) for 25 cycles ± 5% $U_T$ (>95% dip in $U_T$ ) for 5 cycles	Mains power quality should be that of a typical commercial or hospital environment. If the user of the device requires continued operation during power mains interruptions, it is recommended that the device be powered from an uninterruptible power supply or battery pack.
Power Frequency (50/60 Hz) Magnetic Field IEC 61000-4-8	30 A/m	30 A/m	Power frequency magnetic fields should be at levels characteristic of a typical location in a typical commercial or hospital environment.
<b>Note:</b> $U_T$ is the AC mains voltage before application of the test level.			

**Table 11. Guidance and Manufacturer's Declaration—Electromagnetic Immunity**

Immunity Test	IEC 60601 Test Level	Compliance Level	Electromagnetic Environment—Guidance
<i>This device is intended for use in the electromagnetic environment specified below. The user of this device should ensure that it is used in such an environment.</i>			
Portable and mobile RF communications equipment should be used no closer to any part of the device, including cables, than the recommended separation distance calculated from the equation applicable to the frequency of the transmitter.			
Conducted RF IEC 61000-4-6  Radiated RF IEC 61000-4-3	3 Vrms 150 kHz to 80 MHz  3 V/m 80 MHz to 2.7 GHz	3 V  3 V/m	<p style="text-align: center;"><b>Recommended Separation Distance</b></p> $d = 1.17\sqrt{P}$ 80 MHz to 800 MHz $d = 1.17\sqrt{P}$ 800 MHz to 2.7 GHz $d = 2.33\sqrt{P}$ <p>where <math>P</math> is the maximum output power rating of the transmitter in watts (W) according to the transmitter manufacturer and <math>d</math> is the recommended separation distance in meters (m).</p> <p>Field strengths from fixed RF transmitters, as determined by an electromagnetic site survey,<sup>a</sup> should be less than the compliance level in each frequency range.<sup>b</sup></p> <p>Interference may occur in the vicinity of equipment marked with the following symbol:</p> <div style="text-align: center;">  </div>
Radiated RF IEC 61000-4-3	Professional Transport 20 V/m 80% AM 1 kHz modulation 80 MHz to 2.7 GHz	20 V/m	
<b>NOTES:</b> <ul style="list-style-type: none"> <li>At 80 MHz and 800 MHz, the higher frequency range applies.</li> <li>These guidelines may not apply in all situations. Electromagnetic propagation is affected by absorption and reflection from structures, objects, and people.</li> </ul>			

a. Field strengths from fixed transmitters, such as base stations for radio (cellular/cordless) telephones and land mobile radios, amateur radio, AM and FM radio broadcast and TV broadcast cannot be predicted theoretically with accuracy. To assess the electromagnetic environment due to fixed RF transmitters, an electromagnetic site survey should be considered. If the measured field strength in the location in which the device is used exceeds the applicable RF compliance level above, the device should be observed to verify normal operation. If abnormal performance is observed, additional measures may be necessary, such as reorienting or relocating the device.

b. Over the frequency range 150 kHz to 80 MHz, field strengths should be less than 3 V/m.





**Table 12. Recommended Separation Distances**

*This device is intended for use in an electromagnetic environment in which radiated RF disturbances are controlled. Customers or users of this device can help prevent electromagnetic interference by maintaining a minimum distance between portable and mobile RF communication equipment (transmitters) and the device as recommended below, according to maximum output power of the communications equipment.*

Rated Maximum Output Power of Transmitter W	Separation Distance According to Frequency of Transmitter		
	150 kHz to 80 MHz $d = 1.17\sqrt{P}$	80 MHz to 800 MHz $d = 1.17\sqrt{P}$	800 MHz to 2.7 GHz $d = 2.33\sqrt{P}$
0.01	0.12	0.12	0.23
0.1	0.37	0.37	0.74
1	1.2	1.2	2.3
10	3.7	3.7	7.4
100	12	12	23

For transmitters rated at a maximum output power not listed above, the recommended separation distance d in meters (m) can be estimated using the equation applicable to the frequency of the transmitter, where P is the maximum output power rating of the transmitter in watts (W) according to the transmitter manufacturer.

**NOTES:**

- At 80 MHz and 800 MHz, the separation distance for the higher frequency range applies.
- These guidelines may not apply in all situations. Electromagnetic propagation is affected by absorption and reflection from structures, objects, and people.

## Equipment Response Time

If the signal is inadequate, the last measured values freeze for 10 seconds and are then replaced with dashes.

Equipment Delays	Delays
Display Update Delay	2 – 5 seconds
Alarm Signal Generation Delay*	0 – 5 seconds

\*After adjusting the limits, it may take up to 5 seconds for the new limits to take effect.

## System Specifications

<b>Power Requirements:</b>	Power Supply: 100 – 240 VAC 50 – 60 Hz Power Consumption: 3.6 W with battery operation 9 W with power supply Input: 12 VDC, 1.5 A
<b>Internal Battery:</b>	Type: Lithium Ion (Li-Ion) internal battery, non-field replaceable, rechargeable Battery Capacity: Approximately 5 hours Charging Time: Approximately 9 hours
<b>Dimensions:</b>	200 x 135 x 50 mm (7.9 x 5.3 x 2 in.)
<b>Weight:</b>	865 grams (1.9 pounds)
<b>Memory:</b>	36 hours (assuming continuous operation)
<b>Temperature:</b>	Operating: 0 to 40 °C (32 to 104 °F) Storage/Transportation: -40 to 70 °C (-40 to 158 °F) Time (from storage) for monitor to be ready 10 minutes to warm from -40 to 0 °C for its intended use: 19 minutes to cool from 70 to 40 °C Applied part temperature will not exceed 41°C as measured during a controlled environment test.
<b>Humidity:</b>	Operating: 15% to 93% noncondensing Storage/Transportation: Up to 93% noncondensing
<b>Altitude:</b>	Operating: Up to 2,740 meters (9,000 feet) Atmospheric Pressure: 525 to 795 mmHg (700 to 1060 hPa)
<b>Pump:</b>	Pump Flow: 75 ml/min (minimum sample flow rate: 60 ml/min) Flow Accuracy: ±15 ml/min
<b>High and Medium Priority Alarms (at 1 m):</b>	Sound Pressure Level: 74.6 to 75.5 dB
<b>Classification per ANSI/AAMI ES60601-1 and CAN/CSA-C22.2 No. 60601-1:</b>	Type of Protection: Internally powered class II (with power supply) Degree of Protection: Type BF-Applied Part Mode of Operation: Continuous Enclosure Degree of Ingress Protection: IP22



## Capnography Specifications

<b>Respiration Range:</b>	0 to 99 respirations/minute
<b>Respiration Accuracy:</b>	3 to 50 respirations/minute $\pm 2$ 51 to 60 respirations/minute $\pm 3$
Test method summary: To determine the rated respiration rate, calibrated CO <sub>2</sub> gas tanks are used as the respiration rate is changed from 3 to 60 BrPM.	
<b>EtCO<sub>2</sub>/CO<sub>2</sub> Range:</b>	0 to 99 mmHg (0 to 13.2 kPa)
<b>EtCO<sub>2</sub>/CO<sub>2</sub> Accuracy<sup>1,2</sup>:</b>	$\pm 0.2$ kPa / $\pm 2$ mmHg, +8% of reading <sup>3</sup> 525 – 795 mmHg (700 – 1060 hPa) (EtCO <sub>2</sub> /CO <sub>2</sub> reading reaches its steady state accuracy within 10 minutes after power up. From maximum storage temperature, monitor reaches steady state accuracy 19 minutes after power up.)
<b>Calculated Update Frequency:</b>	Once every breath (“NO BREATH” alarm after 30 seconds)
<b>Sampling Rate:</b>	4 Hz (4 times per second)
<b>Total System Response Time:</b>	<7 seconds (includes delay time and rise time)
<b>Drift of Measurement:</b>	Within CO <sub>2</sub> accuracy specifications for 6 hours of continuous monitoring
<b>Measurement:</b>	Automatic barometric pressure compensation and CO <sub>2</sub> temperature compensation

<sup>1</sup> There is no known adverse effect on performance due to cyclical pressure up to 10 kPa.

<sup>2</sup> There is no degradation in EtCO<sub>2</sub> measurement accuracy as a function of BrPM and inspiratory/expiratory (I/E) time ratio.

<sup>3</sup> Presented concentration of CO<sub>2</sub> and EtCO<sub>2</sub> can be false, indicating a high presence of nitrous oxide and other interfering gases.

The table below shows the CO<sub>2</sub> and EtCO<sub>2</sub> concentration corrections. Only use agents listed in the table below.

Agent Concentration	Correction of Presented CO <sub>2</sub> to Real Concentration
50 – 70% N <sub>2</sub> O	Presented CO <sub>2</sub> x 0.75 = Actual CO <sub>2</sub>
30 – 50% N <sub>2</sub> O	Presented CO <sub>2</sub> x 0.85 = Actual CO <sub>2</sub>
0 – 30% N <sub>2</sub> O	No correction